

Year

|

Day 6

# My Book Report for

---

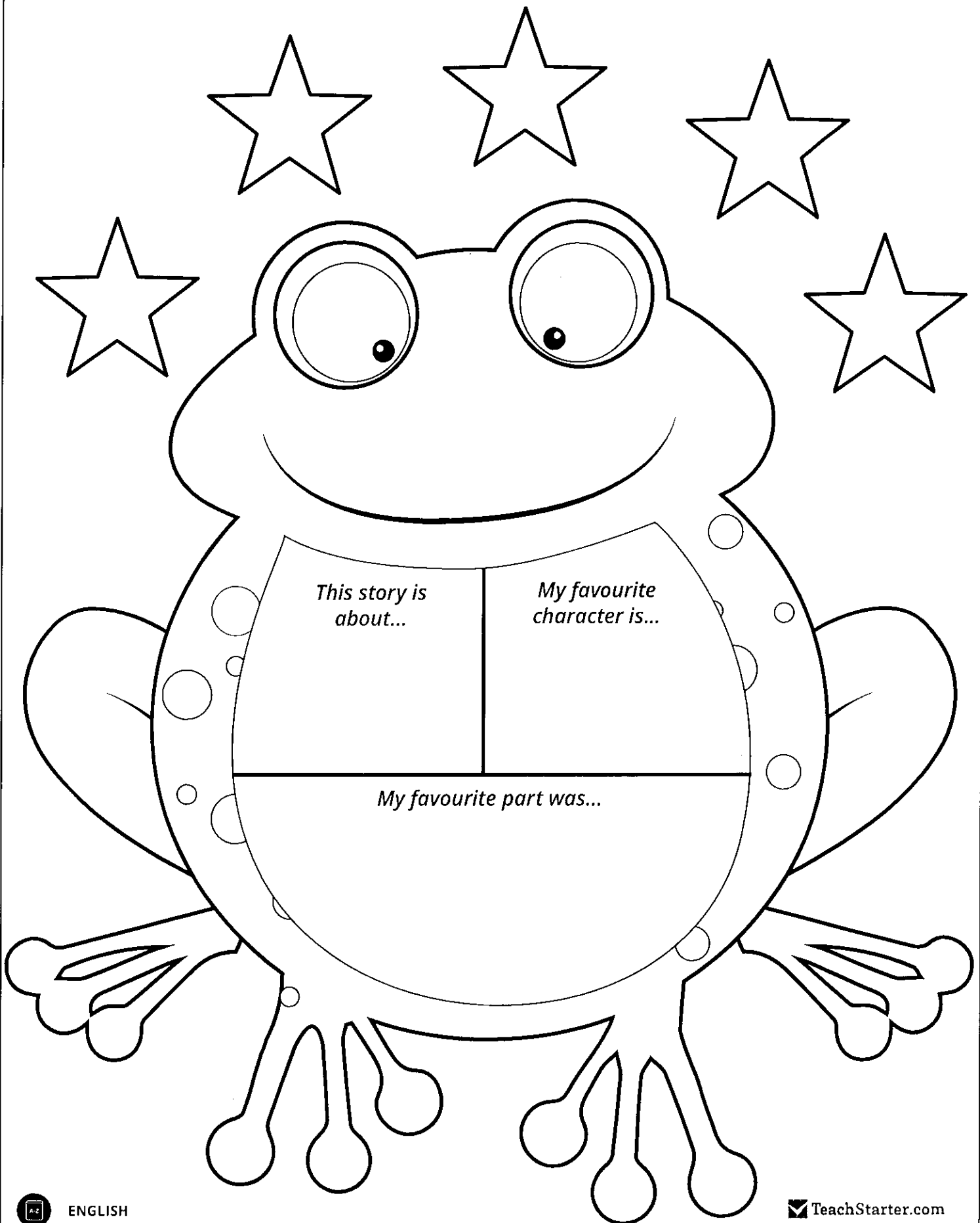

Name: \_\_\_\_\_

Date: \_\_\_\_\_

© Tiny Teaching Shack

# Expand Using Adjectives

A simple sentence shows one complete thought.

A bird flew over my head.

Add an adjective to expand the sentence.

A yellow bird flew over my head.

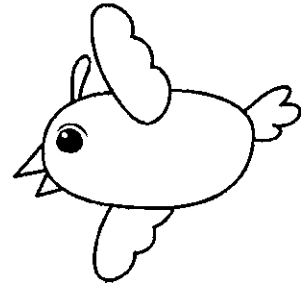

**Direction:** Add the adjective in the box and rewrite the sentence.

1.  I wore a shirt.

\_\_\_\_\_

2.  There are apples on the table.

\_\_\_\_\_

3.  I saw whales in the ocean.

\_\_\_\_\_

4.  She is a lady.

\_\_\_\_\_

5.  I gazed at the moon.

\_\_\_\_\_

**Direction:** Add your own adjective to expand the sentence.

6. I want to eat those \_\_\_\_\_ cookies again.

7. A \_\_\_\_\_ bear looked for berries in the woods.

Name: \_\_\_\_\_ Date: \_\_\_\_\_

sh

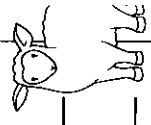

Colour in the pictures that have a 'sh' sound in them.

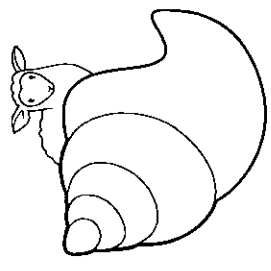
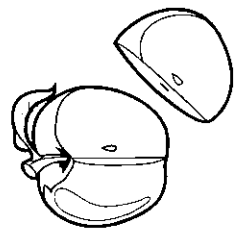
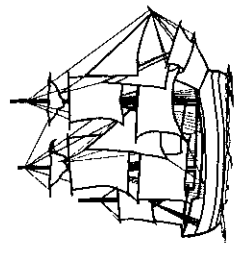
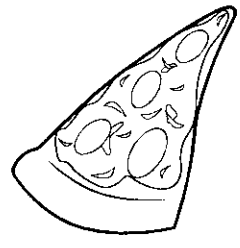
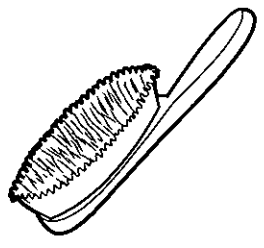
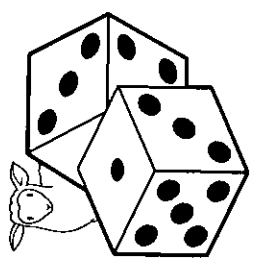
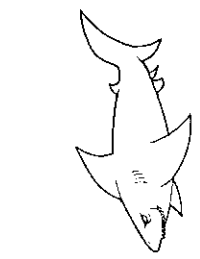

Write a sign for the shop.

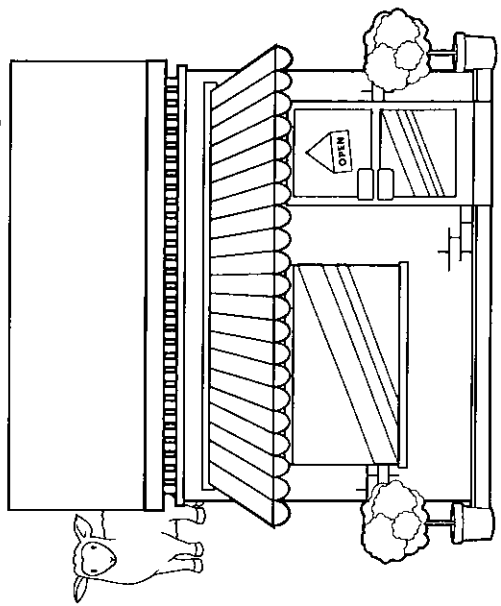

Add 'sh' to make a word.

pu \_\_\_\_\_

wi \_\_\_\_\_

wa \_\_\_\_\_

\_\_\_\_\_ ake

Circle the 'sh' words in the sentence below.

She wished she could wash her pet shark.



Find 5 sheep hidden on this page.

Name: \_\_\_\_\_

Ff

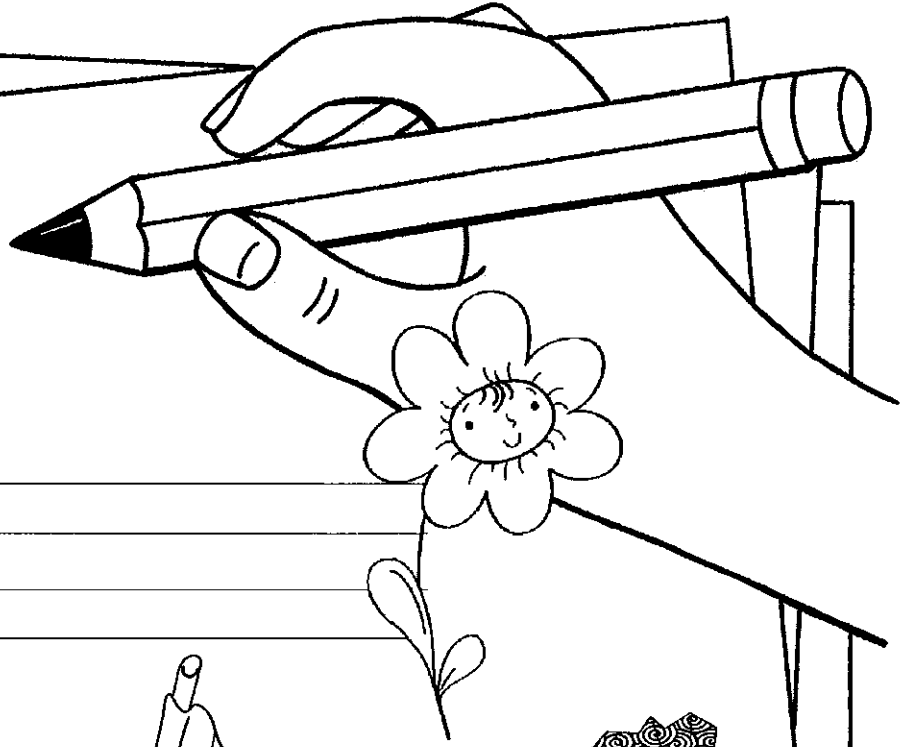

f f f f

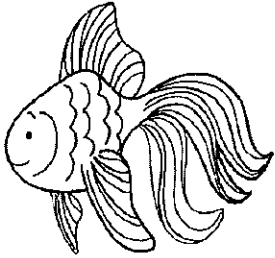

fish

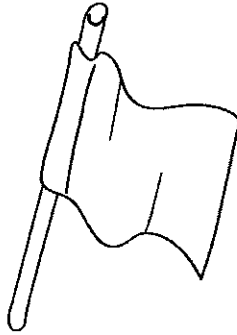

flag

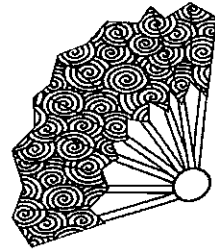

fan

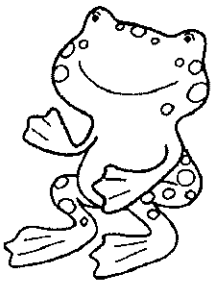

frog

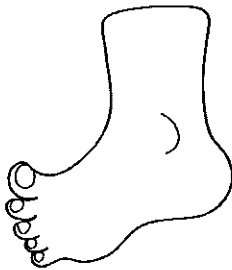

foot



fox

Name: \_\_\_\_\_ Date: \_\_\_\_\_

12  
 twelve

What comes before and after 12?

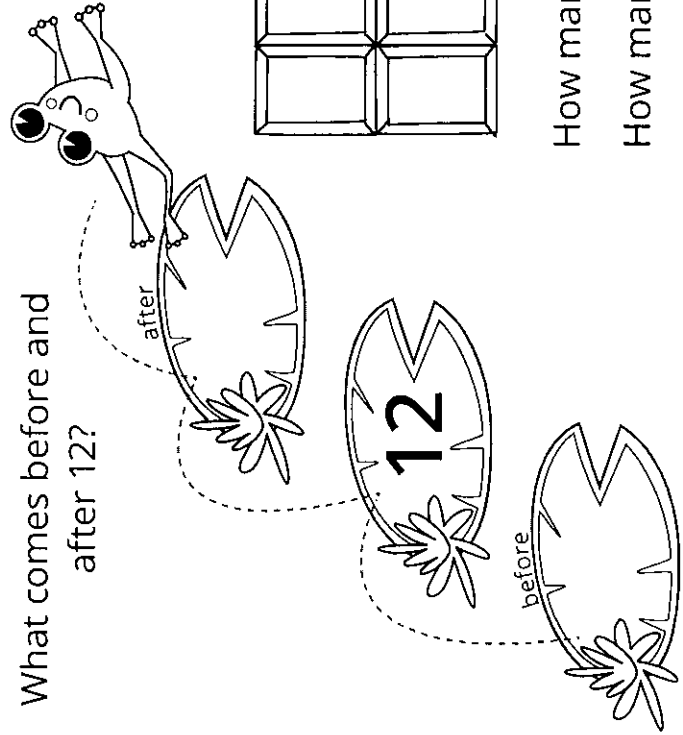

Colour in 12 pieces of this chocolate bar.

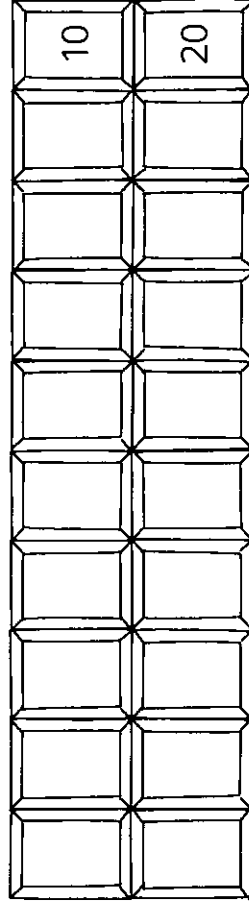

How many chocolate squares more than 10? \_\_\_\_\_  
 How many chocolate squares less than 20? \_\_\_\_\_

Write 12 in the correct houses.

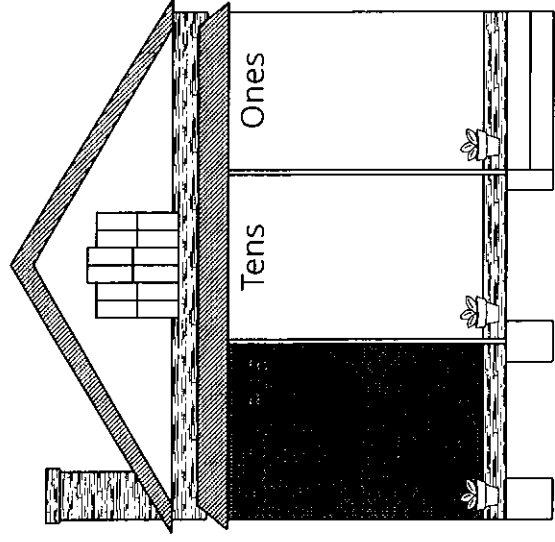

Name: \_\_\_\_\_

# Backward Strips

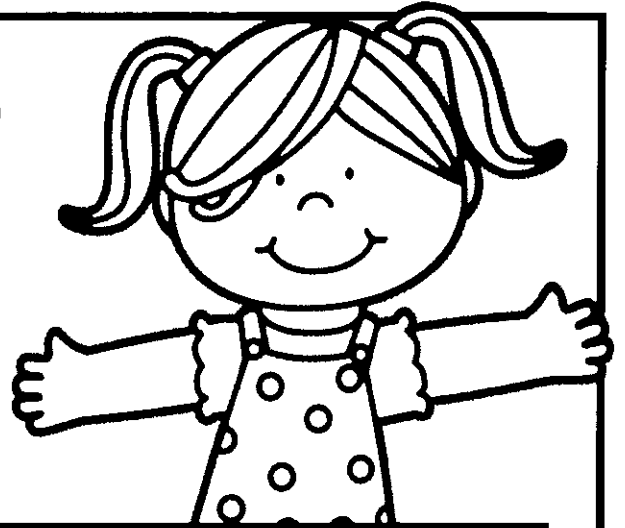

Count backwards to complete the number sequence.

49	48		46		44	43	
----	----	--	----	--	----	----	--

32		30			27		25
----	--	----	--	--	----	--	----

	75	74		72	71		
--	----	----	--	----	----	--	--

28			25			22	21
----	--	--	----	--	--	----	----

60	59			56	55		
----	----	--	--	----	----	--	--

		84	83			80	
--	--	----	----	--	--	----	--

96	95				91		89
----	----	--	--	--	----	--	----

71		69		67		65	
----	--	----	--	----	--	----	--



Addition to ten.

Finish in your own colours.

WRITE THE SUM

2 squares and 3 triangles. How many altogether?

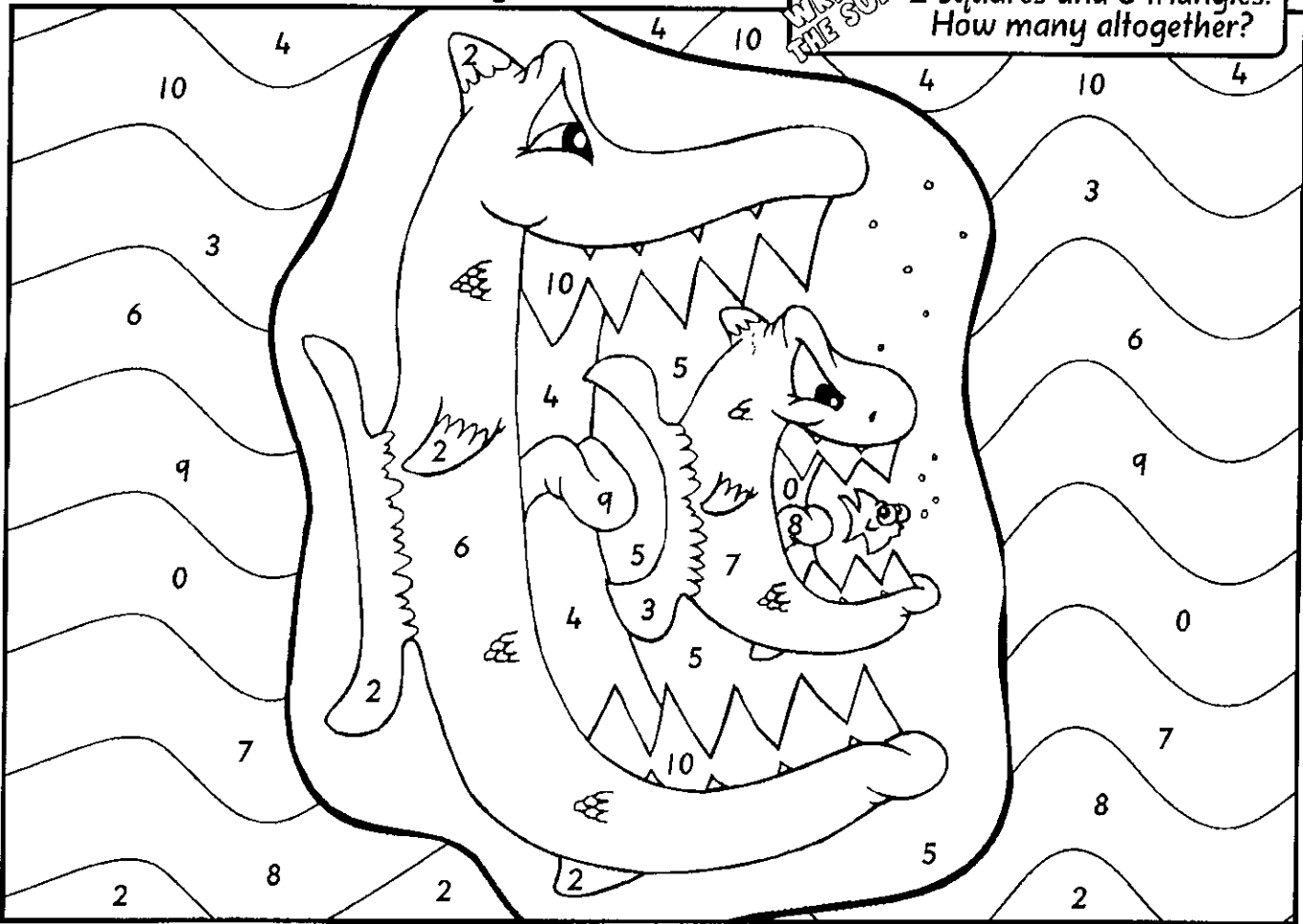

Look for the numbers more than once and colour the picture.

$1 + 1 = \bigcirc$ blue	$2 + 6 = \bigcirc$ green
$1 + 3 = \bigcirc$ pink	$5 + 2 = \bigcirc$ rainbow
$2 + 4 = \bigcirc$ orange	$0 + 0 = \bigcirc$ brown
$4 + 1 = \bigcirc$ black	$1 + 2 = \bigcirc$ purple
$2 + 8 = \bigcirc$ yellow	$4 + 5 = \bigcirc$ red



Day 7

# My Book Report for

---

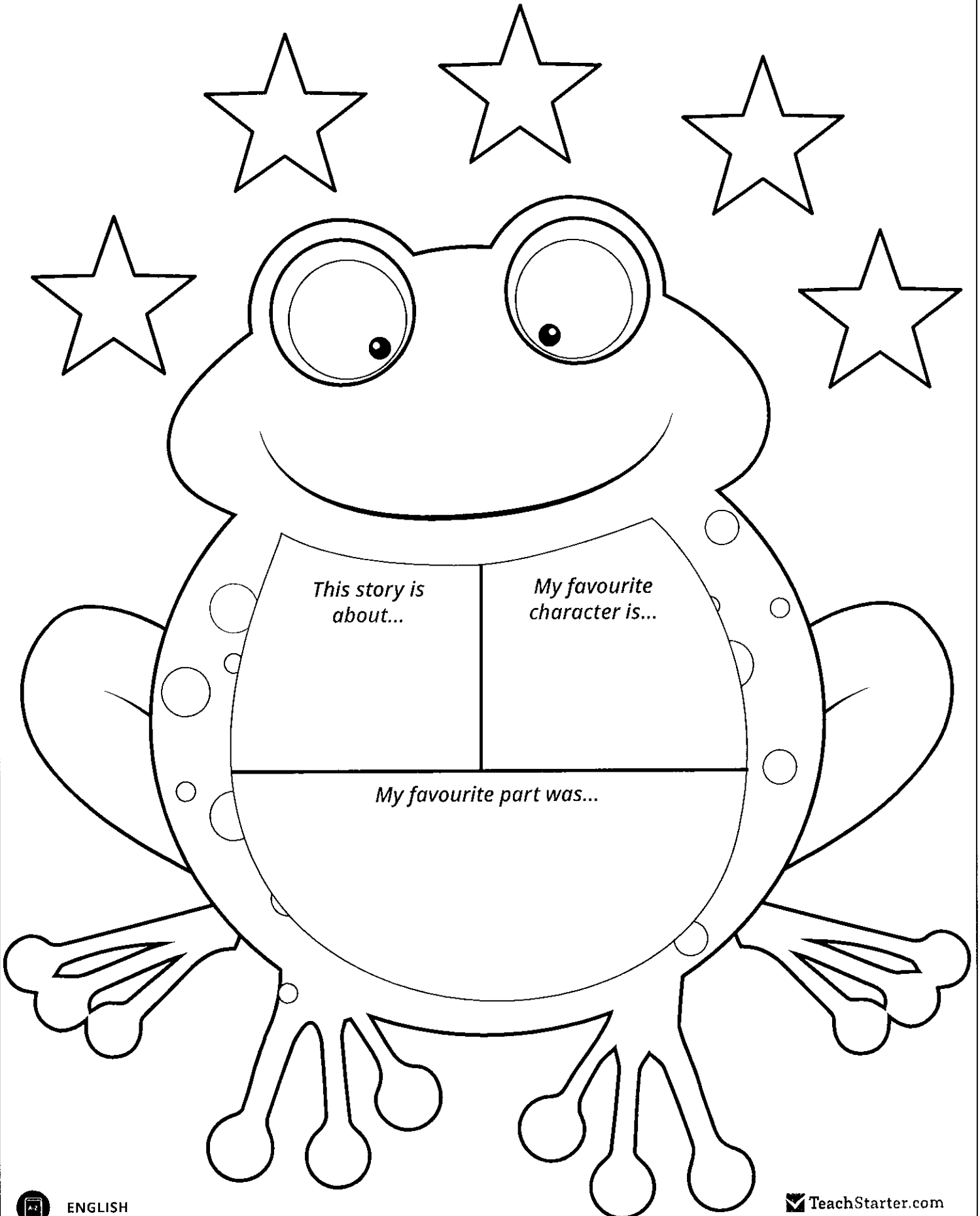

Name: \_\_\_\_\_

Date: \_\_\_\_\_

© Tiny Teaching Shack

# Expand Using Adverbs

A simple sentence shows one complete thought.

I opened the big box.

Add an adverb to expand the sentence.

I nervously opened the big box.

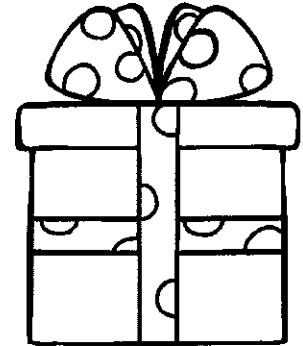

**Direction:** Add the adverb in the box and rewrite the sentence.

1.  My brother sang.

\_\_\_\_\_

2.  Tom studied for his math test.

\_\_\_\_\_

3.  She played the drums.

\_\_\_\_\_

4.  He whispered to me.

\_\_\_\_\_

5.  I skipped all the way home.

\_\_\_\_\_

**Direction:** Add your own adverb to expand the sentence.

6. The children played \_\_\_\_\_.

7. The band marched \_\_\_\_\_.

Name: \_\_\_\_\_ Date: \_\_\_\_\_

ar

Draw something that could go in this jar.

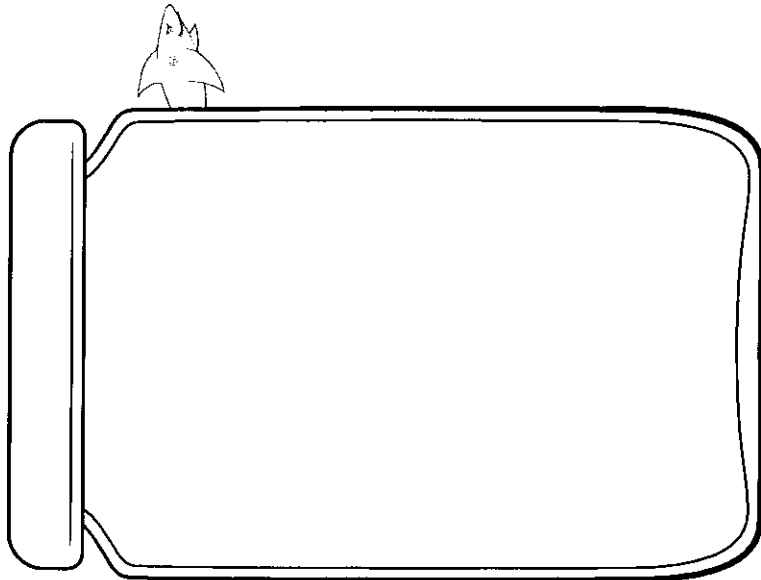

Colour and cut out the farm animals below, and glue them around the barn.

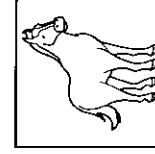
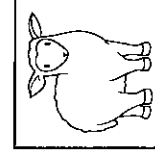
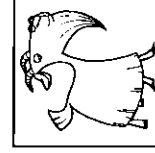
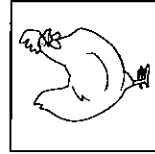
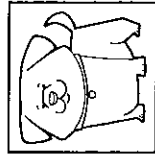
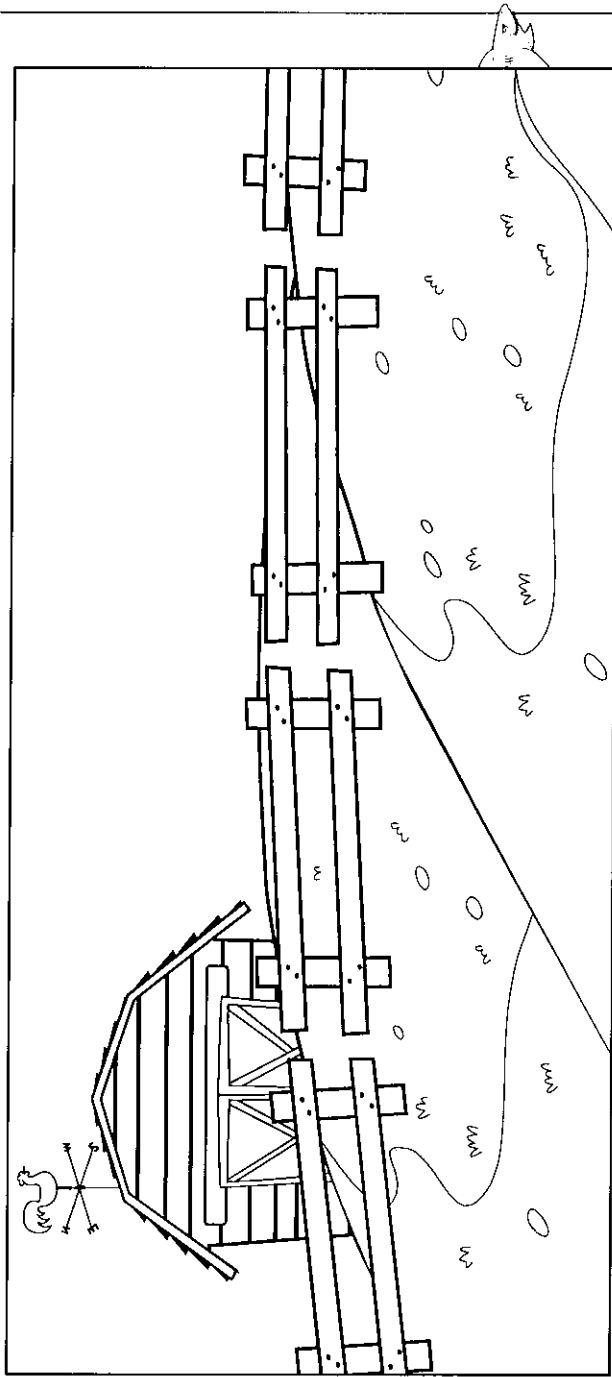

Name: \_\_\_\_\_

Gg

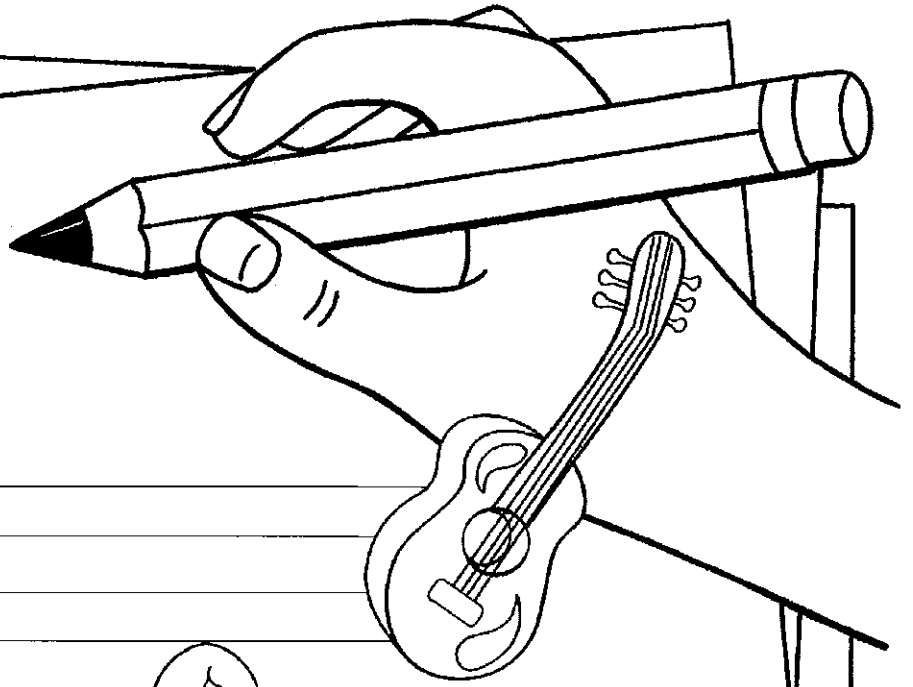

g g g g

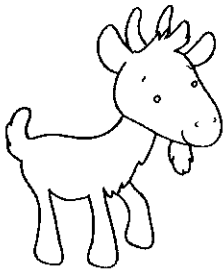

goat



girl

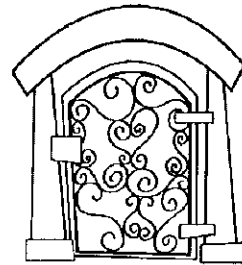

gate



gift

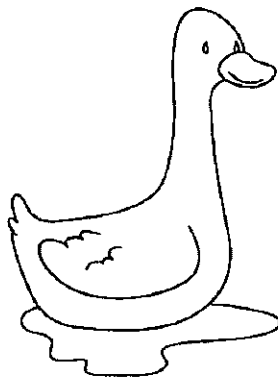

goose



gorilla

Name: \_\_\_\_\_ Date: \_\_\_\_\_

13

thirteen

What comes before and after 13?

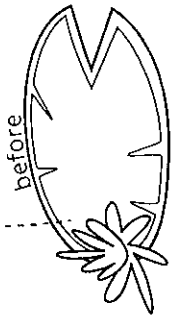
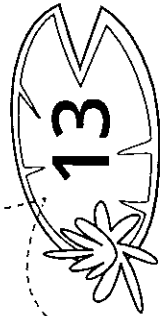
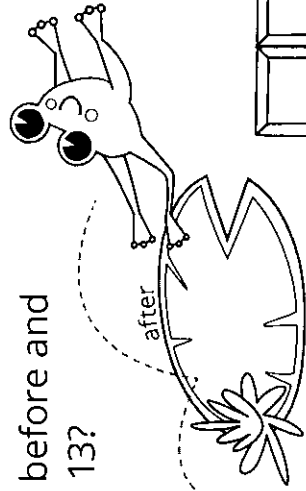

Colour in 13 pieces of this chocolate bar.

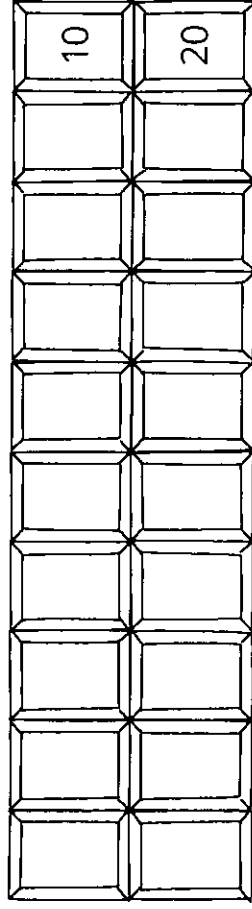

How many chocolate squares more than 10? \_\_\_\_\_

How many chocolate squares less than 20? \_\_\_\_\_

Write 13 in the correct houses.

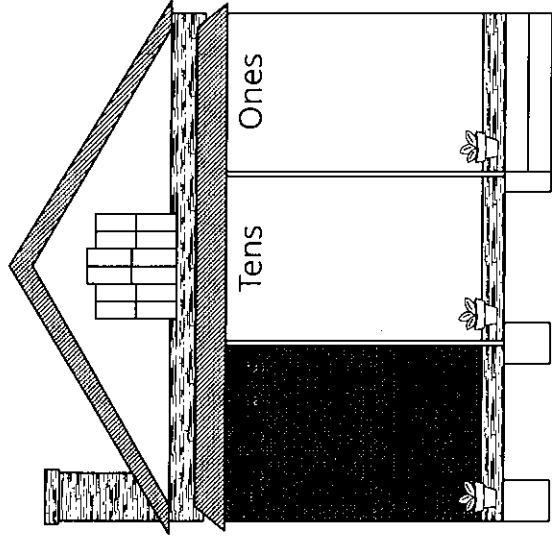



Name: \_\_\_\_\_

# Count It On

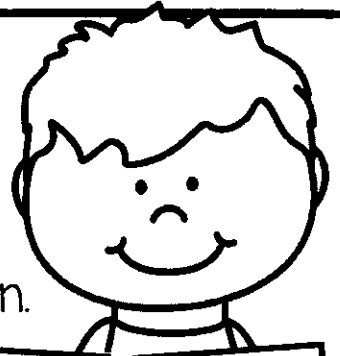

Roll 1 or 2 die, write the number and count it on.

_____					
_____					
_____					
_____					
_____					
_____					
_____					
_____					

Addition to ten.

Finish in your own colours.

WRITE THE SUM

8 cartons and 1 bottle.  
How many altogether?

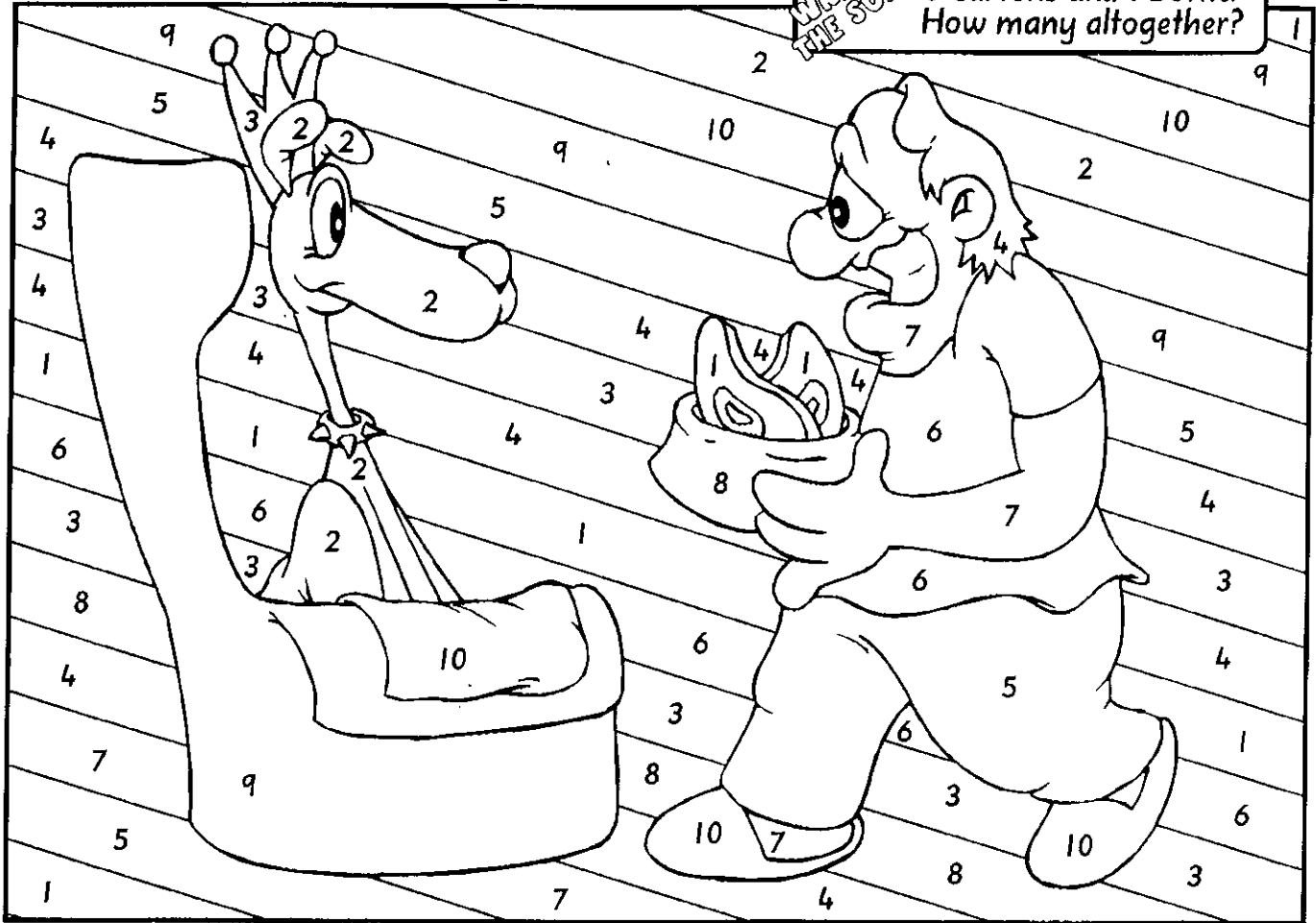

Look for the numbers more than once and colour the picture.

$1 + 4 = \bigcirc$ blue	$3 + 6 = \bigcirc$ green
$4 + 3 = \bigcirc$ pink	$5 + 5 = \bigcirc$ rainbow
$0 + 4 = \bigcirc$ orange	$2 + 0 = \bigcirc$ brown
$4 + 4 = \bigcirc$ black	$3 + 3 = \bigcirc$ purple
$2 + 1 = \bigcirc$ yellow	$1 + 0 = \bigcirc$ red

# EUOPLIOCEPHALUS

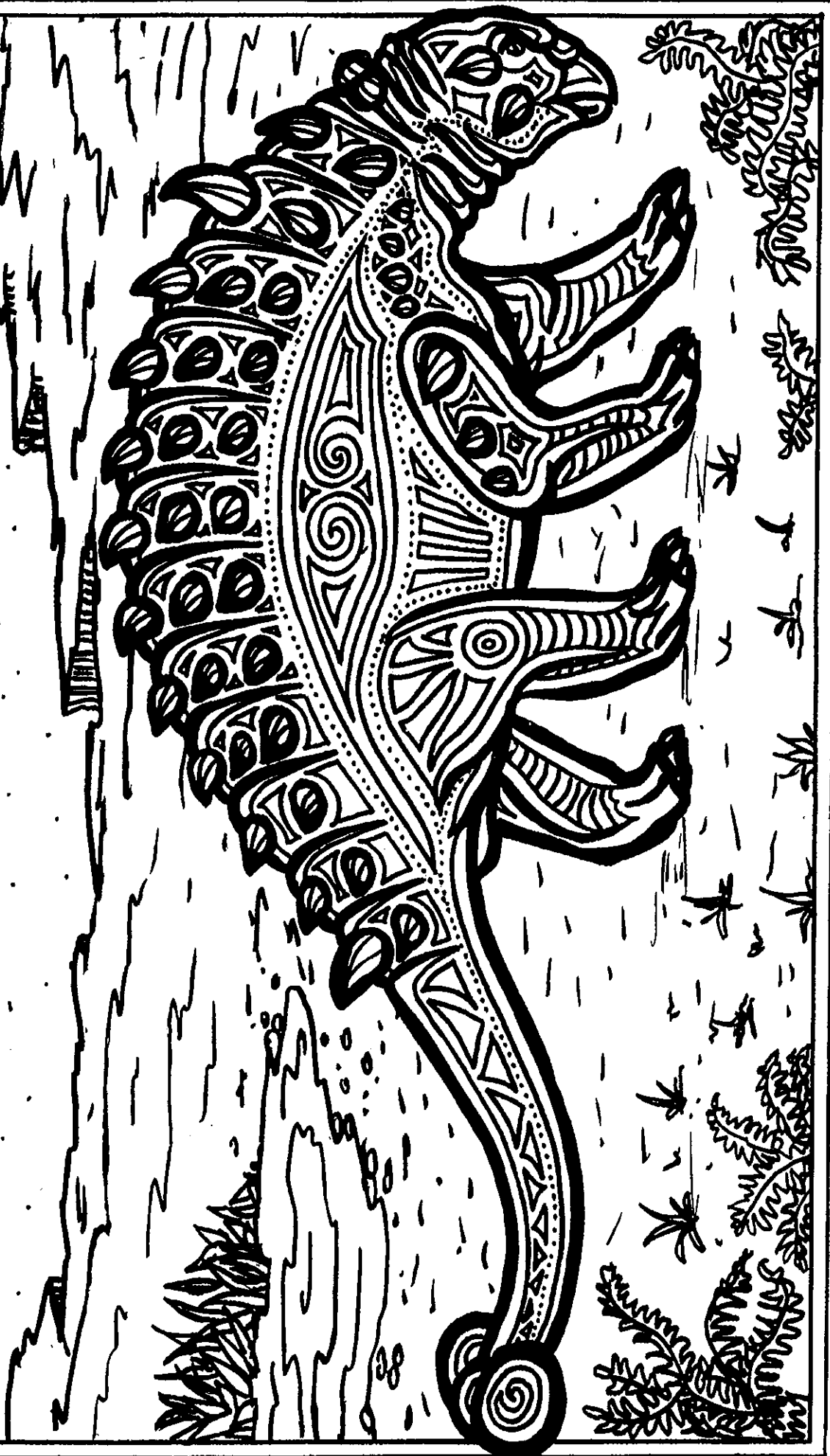

Day 8

# My Book Report for

---

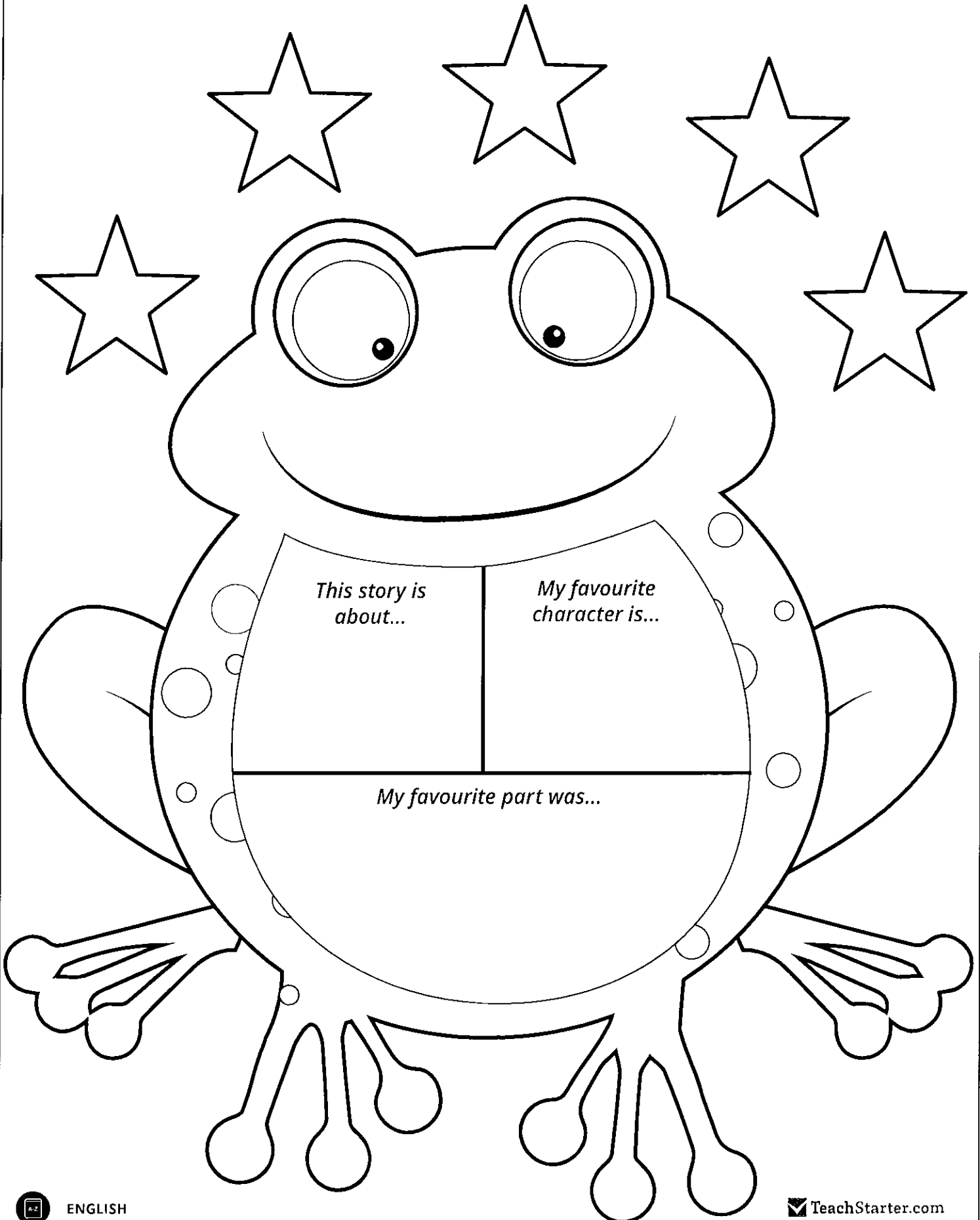

Name: \_\_\_\_\_

Date: \_\_\_\_\_

© Tiny Teaching Shack

# Expand Using Time

A simple sentence shows one complete thought.

He usually takes a nap.

Add a time word or phrase to expand the sentence.

He usually takes a nap after lunch.

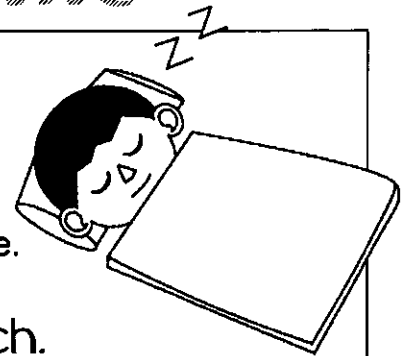

**Direction:** Add the 'time' word or phrase in the box and rewrite the sentence.

1.  We will go to a concert.

\_\_\_\_\_

2.  I woke up very early.

\_\_\_\_\_

3.  I saw Vanessa at the mall.

\_\_\_\_\_

4.  Kate's little sister was born.

\_\_\_\_\_

5.  He returned home.

\_\_\_\_\_

**Direction:** Add your own 'time' word or phrase to expand the sentence.

6. My family adopted a puppy \_\_\_\_\_.

7. I will make a strawberry smoothie \_\_\_\_\_.

Name: \_\_\_\_\_

Date: \_\_\_\_\_

**er**

Complete the dot-to-dot activity below and write the answer, which includes 'er', at bottom.



c \_ \_ t \_ \_ \_ p \_ \_ || \_ \_ r

Fill in the 'er' words below.

f \_ \_ \_ n

tig \_ \_ \_

ott \_ \_ \_

butt \_ \_ \_

teach \_ \_ \_

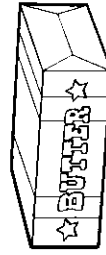

Name: \_\_\_\_\_

Hh

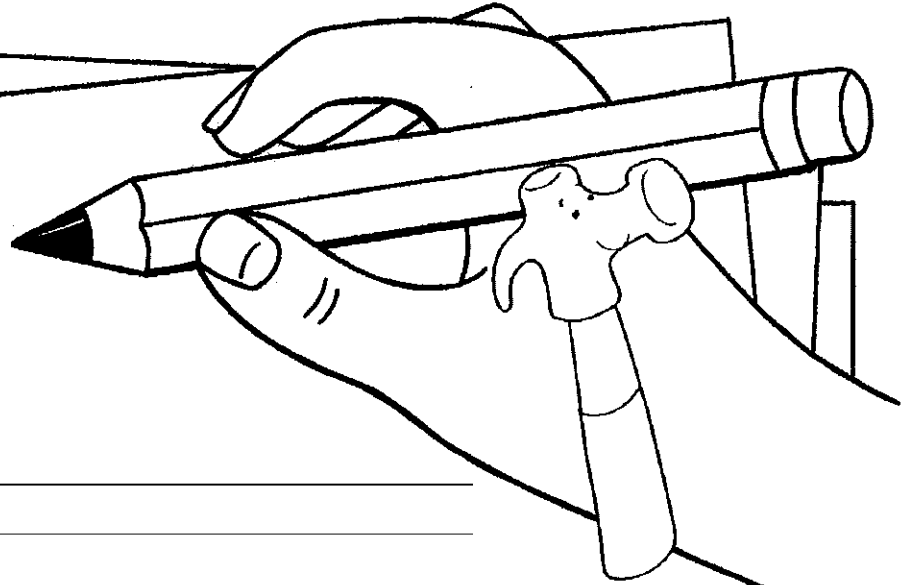

h h h h

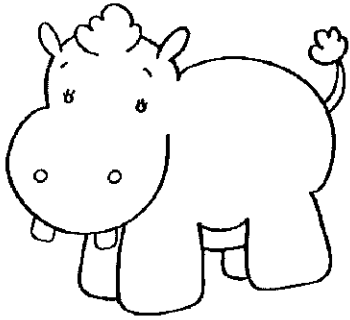

hippo

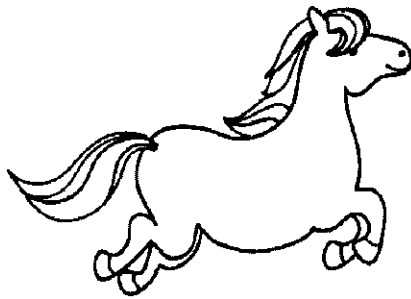

horse



hook

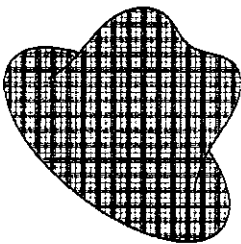

hat

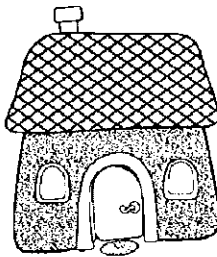

house

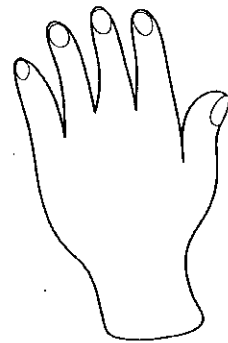

hand



Name: \_\_\_\_\_ Date: \_\_\_\_\_

14

fourteen

What comes before and after 14?

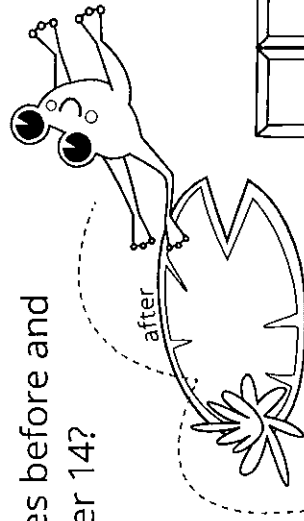

after



before



Colour in 14 pieces of this chocolate bar.

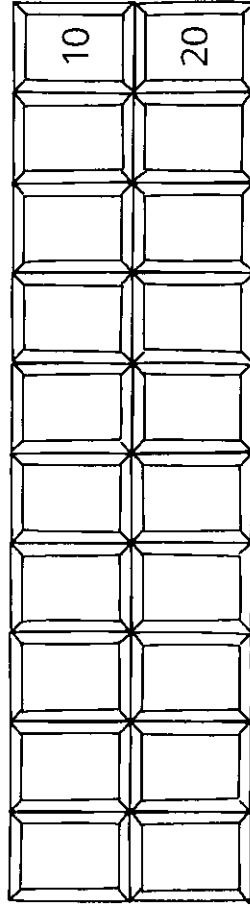

How many chocolate squares more than 10? \_\_\_\_\_

How many chocolate squares less than 20? \_\_\_\_\_

Write 14 in the correct houses.

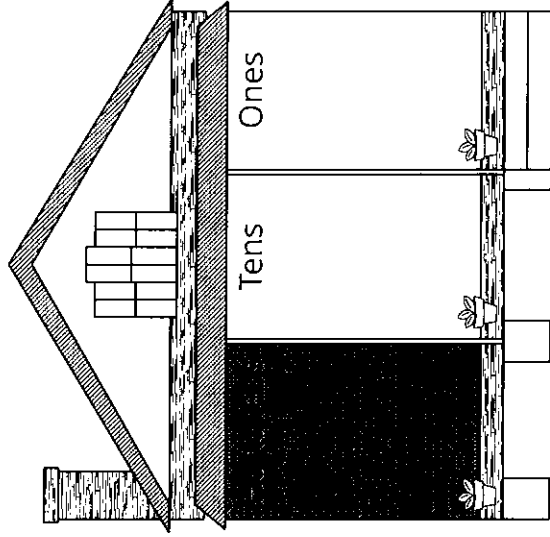

Name: \_\_\_\_\_

# Before and After

Write the number that comes before and after.

	15	
--	----	--

	7	
--	---	--

	9	
--	---	--

	16	
--	----	--

	17	
--	----	--

	11	
--	----	--

	4	
--	---	--

	19	
--	----	--

	5	
--	---	--

	6	
--	---	--

	12	
--	----	--

	14	
--	----	--

	18	
--	----	--

	9	
--	---	--

	8	
--	---	--

	13	
--	----	--

	3	
--	---	--

	10	
--	----	--

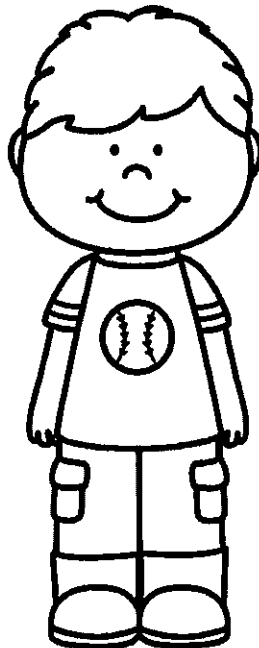
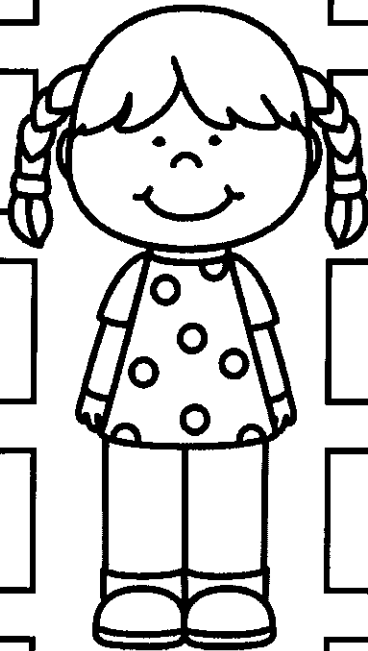

Addition to ten.

Finish in your own colours.

WRITE THE SUM

6 tadpoles and 4 frogs.  
How many altogether?

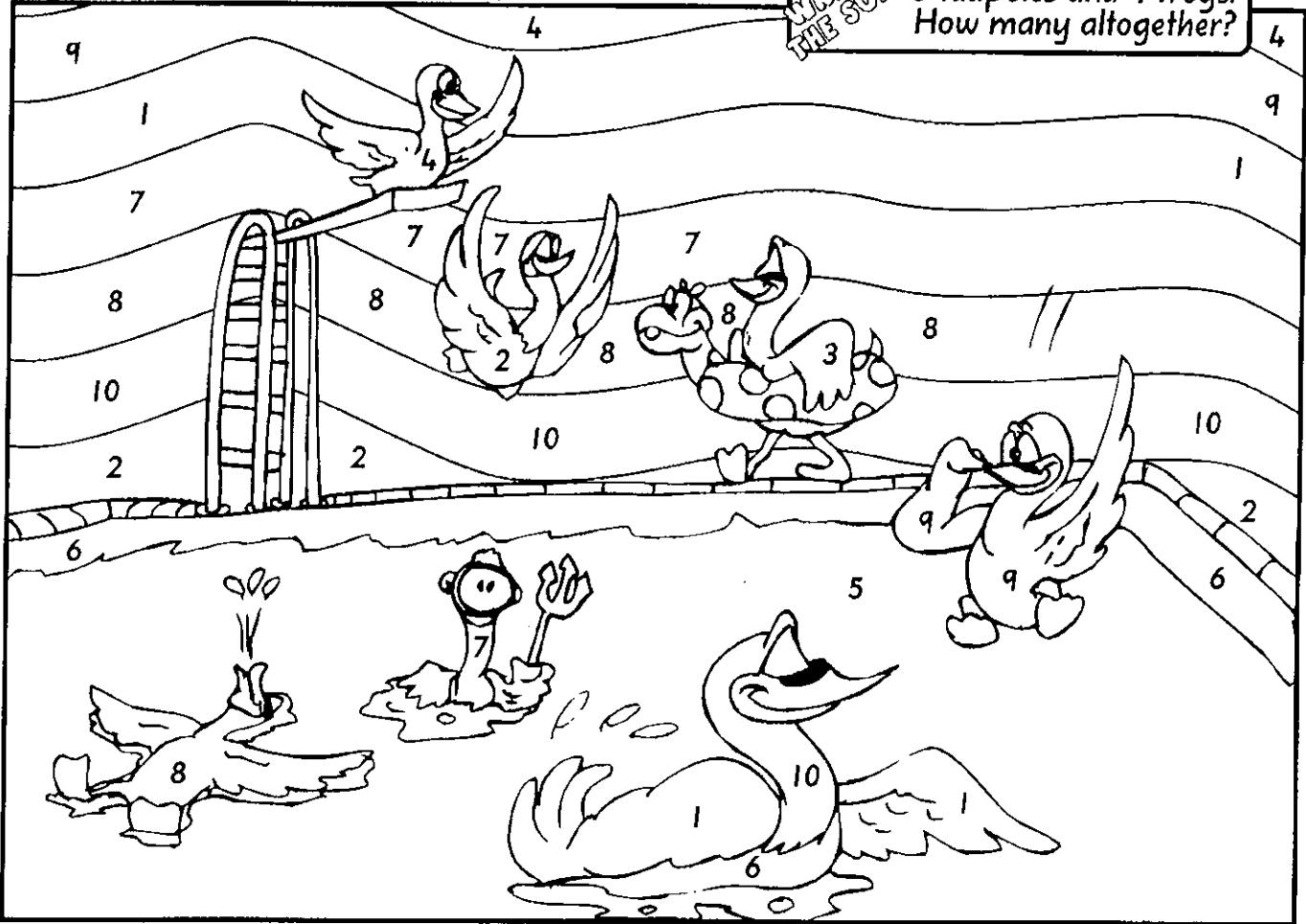

Look for the numbers more than once and colour the picture.

<p>blue</p> $\begin{array}{r} 2 \\ + 3 \\ \hline \end{array}$	<p>green</p> $\begin{array}{r} 5 \\ + 1 \\ \hline \end{array}$	<p>red</p> $\begin{array}{r} 4 \\ + 5 \\ \hline \end{array}$	<p>yellow</p> $\begin{array}{r} 1 \\ + 0 \\ \hline \end{array}$	<p>purple</p> $\begin{array}{r} 5 \\ + 5 \\ \hline \end{array}$
<p>pink</p> $\begin{array}{r} 0 \\ + 8 \\ \hline \end{array}$	<p>orange</p> $\begin{array}{r} 1 \\ + 1 \\ \hline \end{array}$	<p>black</p> $\begin{array}{r} 1 \\ + 2 \\ \hline \end{array}$	<p>brown</p> $\begin{array}{r} 3 \\ + 1 \\ \hline \end{array}$	<p>rainbow</p> $\begin{array}{r} 3 \\ + 4 \\ \hline \end{array}$

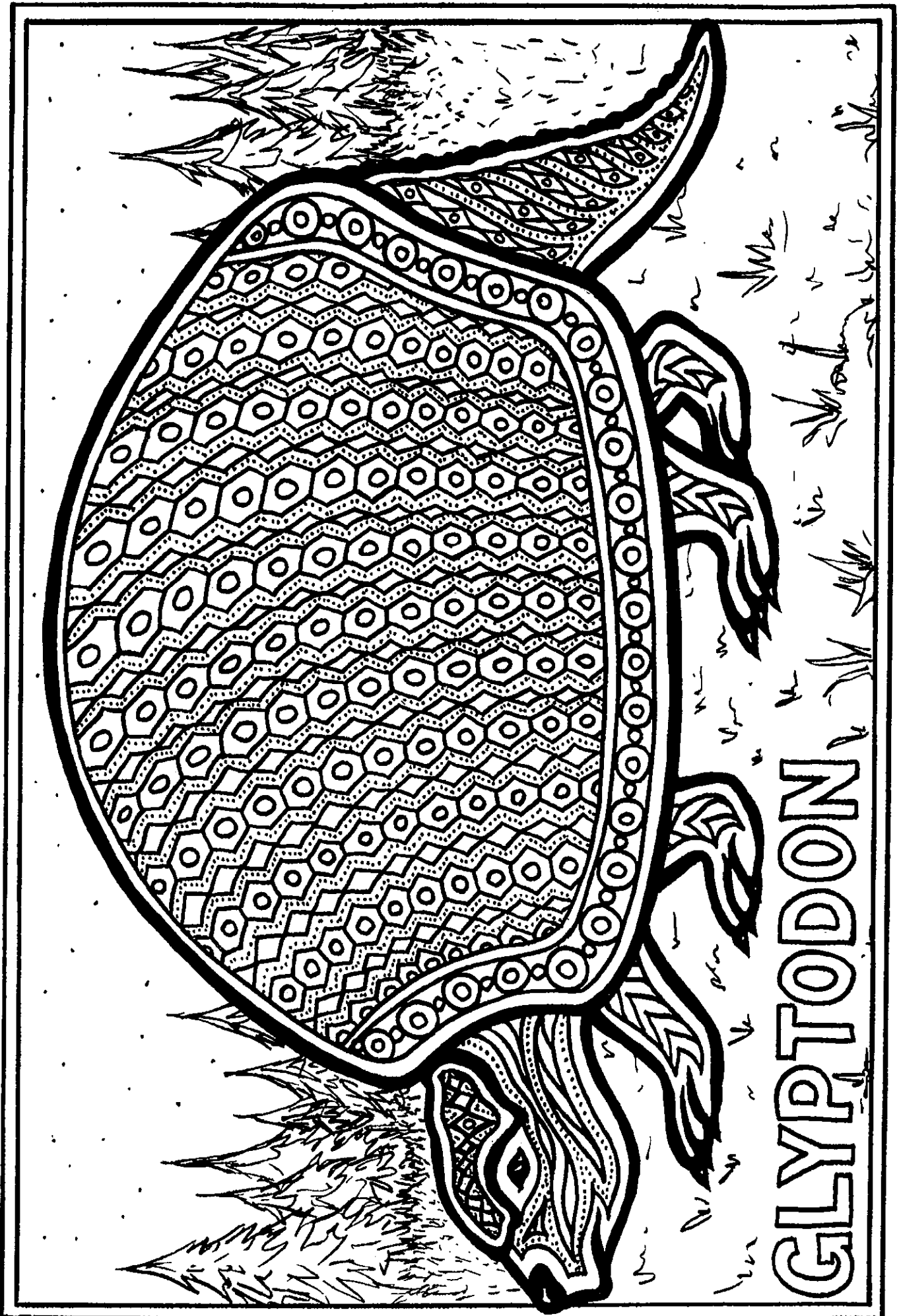

GLYPTODON

Day 9

# My Book Report for

---

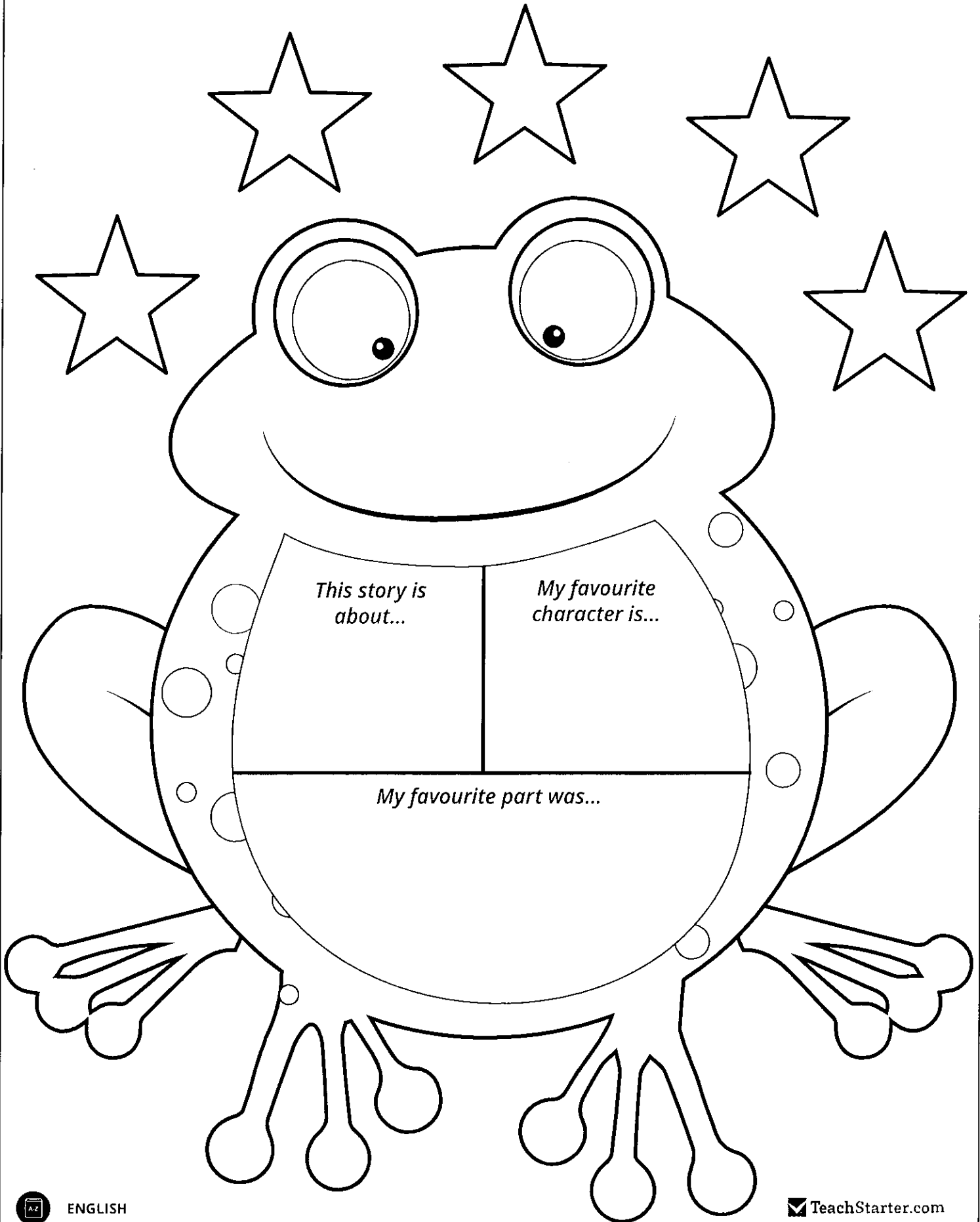

Name: \_\_\_\_\_

Date: \_\_\_\_\_

© Tiny Teaching Shack

# Expand Using Places

A simple sentence shows one complete thought.

Lily sat on a wooden chair.

Add a place word to expand the sentence.

Lily sat on a wooden chair next to the board.

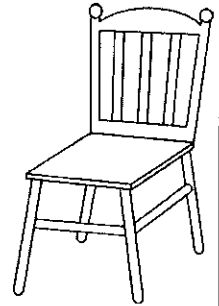

**Direction:** Add the 'place' word in the box and rewrite the sentence.

1.  We played volleyball.

\_\_\_\_\_

2.  Dad picked me up this morning.

\_\_\_\_\_

3.  I decorated a tree.

\_\_\_\_\_

4.  Will you meet me at three?

\_\_\_\_\_

5.  Roger was hiding.

\_\_\_\_\_

**Direction:** Add your own 'place' word or phrase to expand the sentence.

6. Hans and I built a bird house \_\_\_\_\_.

7. A hungry lion crouched and hid \_\_\_\_\_.

Name: \_\_\_\_\_ Date: \_\_\_\_\_

**ir**

In the word search below, find the 'ir' words listed at the bottom.

g	d	b	i	r	d	s	m
t	e	w	u	j	k	t	b
h	v	c	n	t	y	i	o
i	x	z	c	h	i	r	p
r	t	l	s	i	n	b	l
s	e	g	i	r	l	s	h
t	m	o	j	d	i	f	a
y	r	s	b	u	f	g	e

birds stir third chirp girls thirsty

Draw your own T-shirt design that includes something with 'ir' in its name.

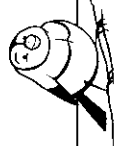
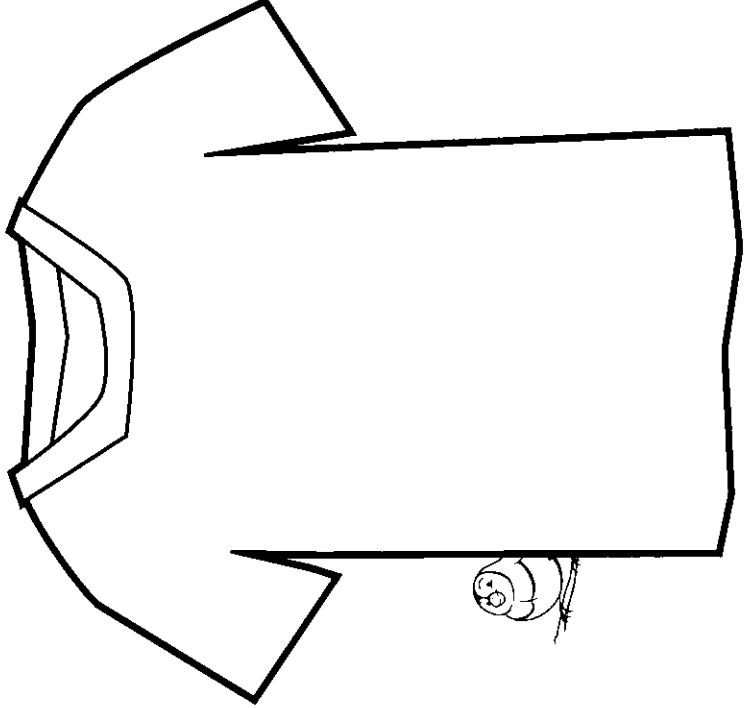



Name: \_\_\_\_\_

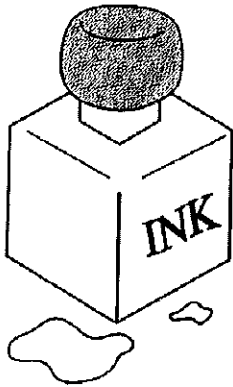
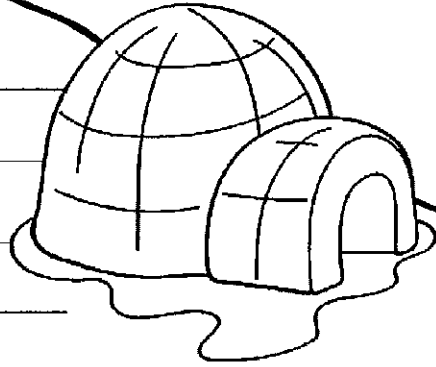
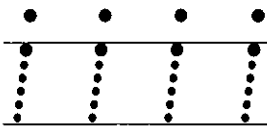
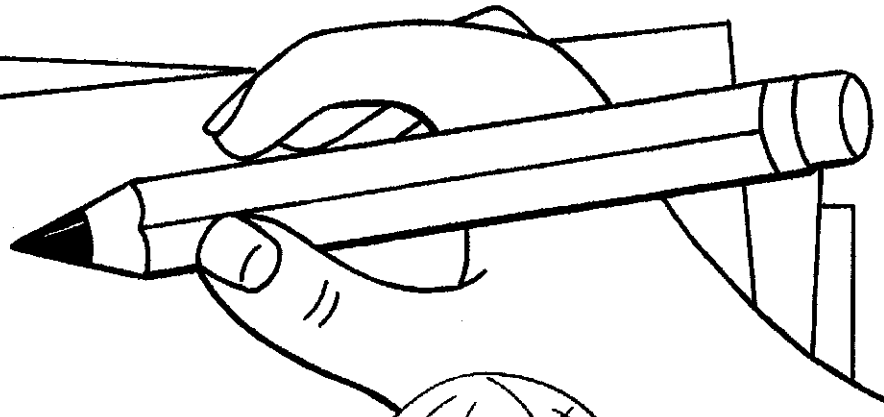
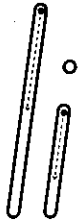

ink

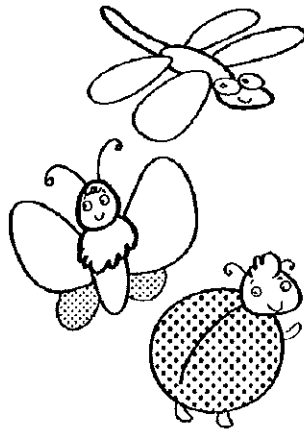

insect

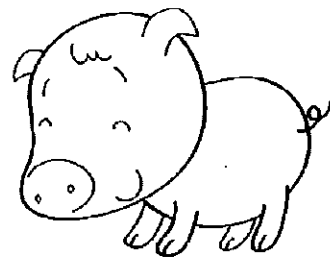

pig



sit

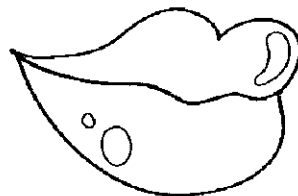

lip

Name: \_\_\_\_\_ Date: \_\_\_\_\_

15

fifteen

What comes before and after 15?

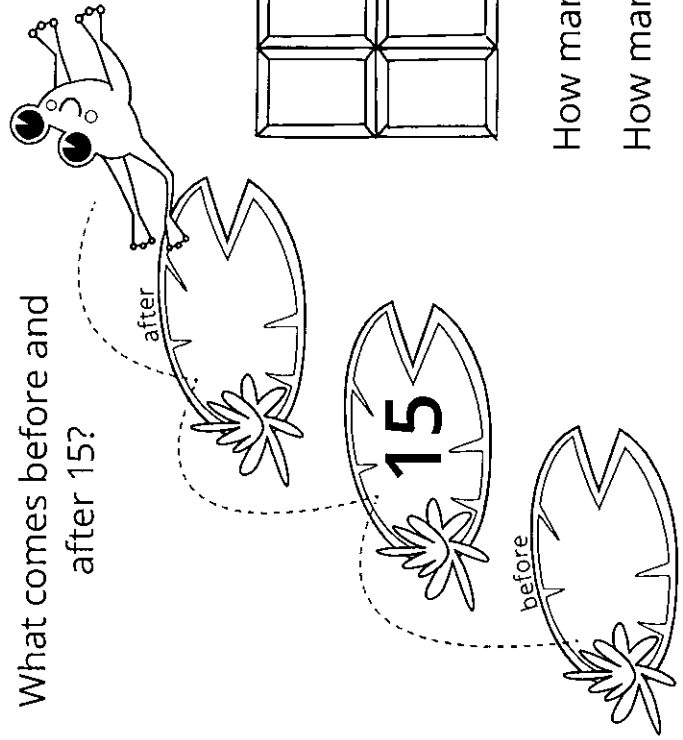

Colour in 15 pieces of this chocolate bar.

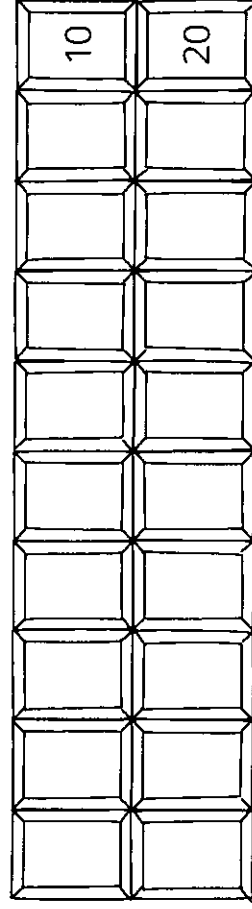

How many chocolate squares more than 10? \_\_\_\_\_  
 How many chocolate squares less than 20? \_\_\_\_\_

Write 15 in the correct houses.

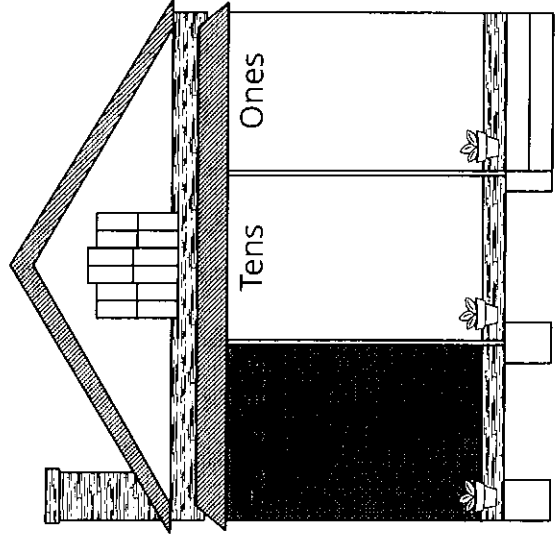

Name: \_\_\_\_\_

# Number Order

Write the numbers that come before and after.

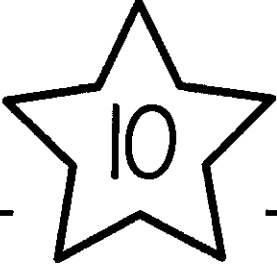

Addition to ten.

Finish in your own colours.

WRITE THE SUM

2 wallabies and 7 koalas.  
How many altogether?

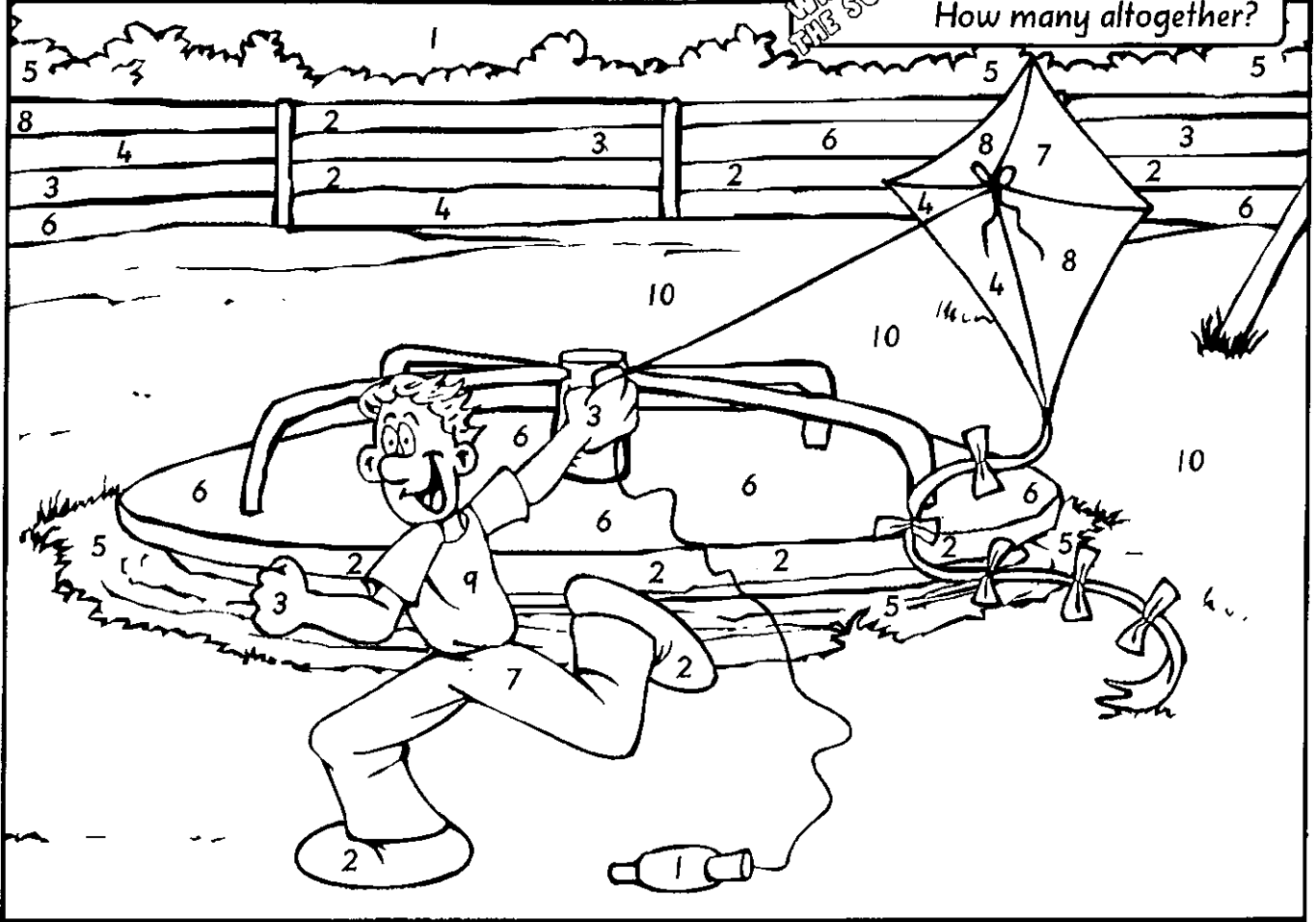

Look for the numbers more than once and colour the picture.

<p>blue</p> $\begin{array}{r} 1 \\ + 0 \\ \hline \end{array}$	<p>green</p> $\begin{array}{r} 5 \\ + 5 \\ \hline \end{array}$	<p>red</p> $\begin{array}{r} 3 \\ + 4 \\ \hline \end{array}$	<p>yellow</p> $\begin{array}{r} 2 \\ + 2 \\ \hline \end{array}$	<p>purple</p> $\begin{array}{r} 4 \\ + 2 \\ \hline \end{array}$
<p>pink</p> $\begin{array}{r} 2 \\ + 1 \\ \hline \end{array}$	<p>orange</p> $\begin{array}{r} 4 \\ + 4 \\ \hline \end{array}$	<p>black</p> $\begin{array}{r} 1 \\ + 1 \\ \hline \end{array}$	<p>brown</p> $\begin{array}{r} 3 \\ + 2 \\ \hline \end{array}$	<p>rainbow</p> $\begin{array}{r} 6 \\ + 3 \\ \hline \end{array}$

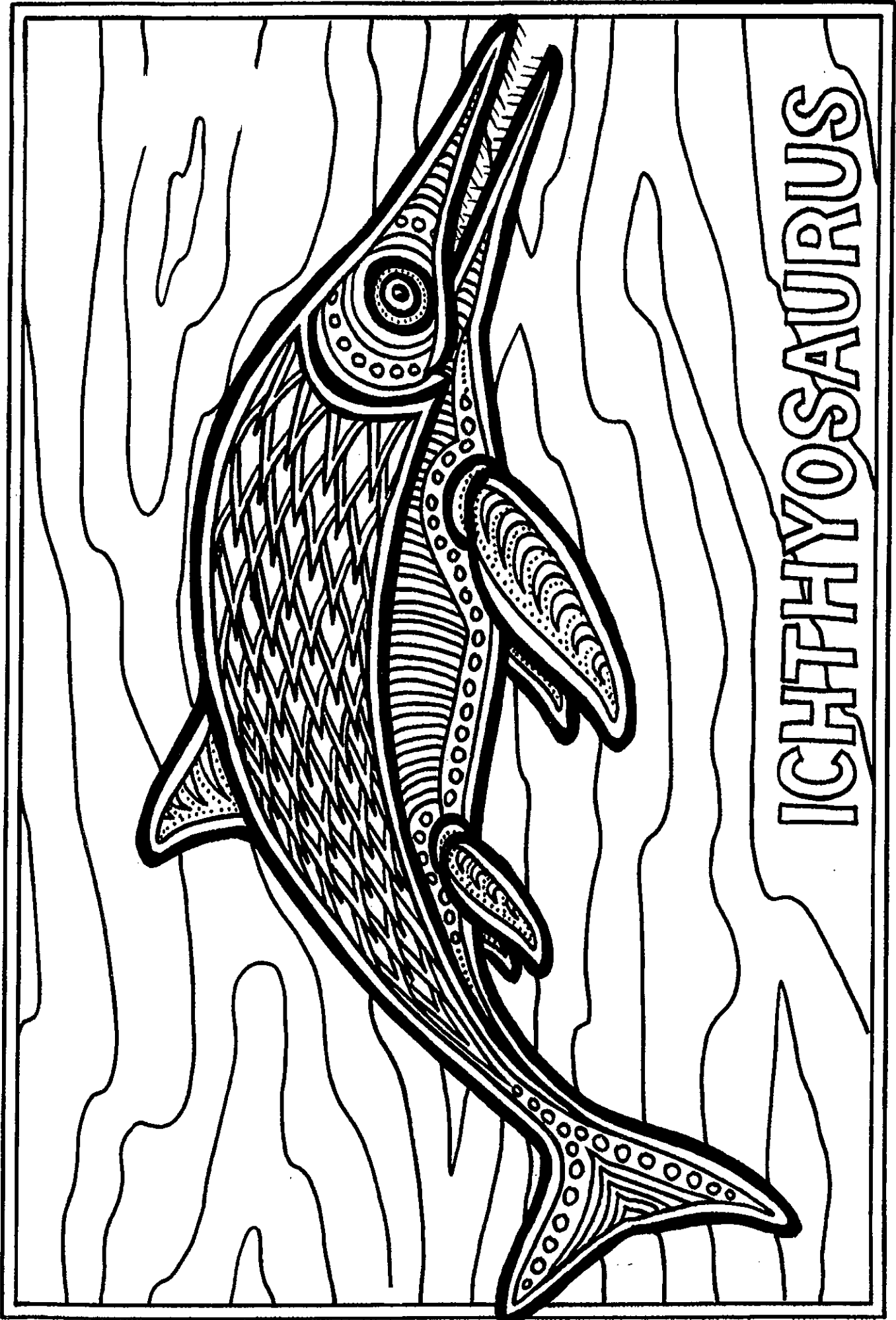

ICHTHYOSAURUS

Day 10

# My Book Report for

---

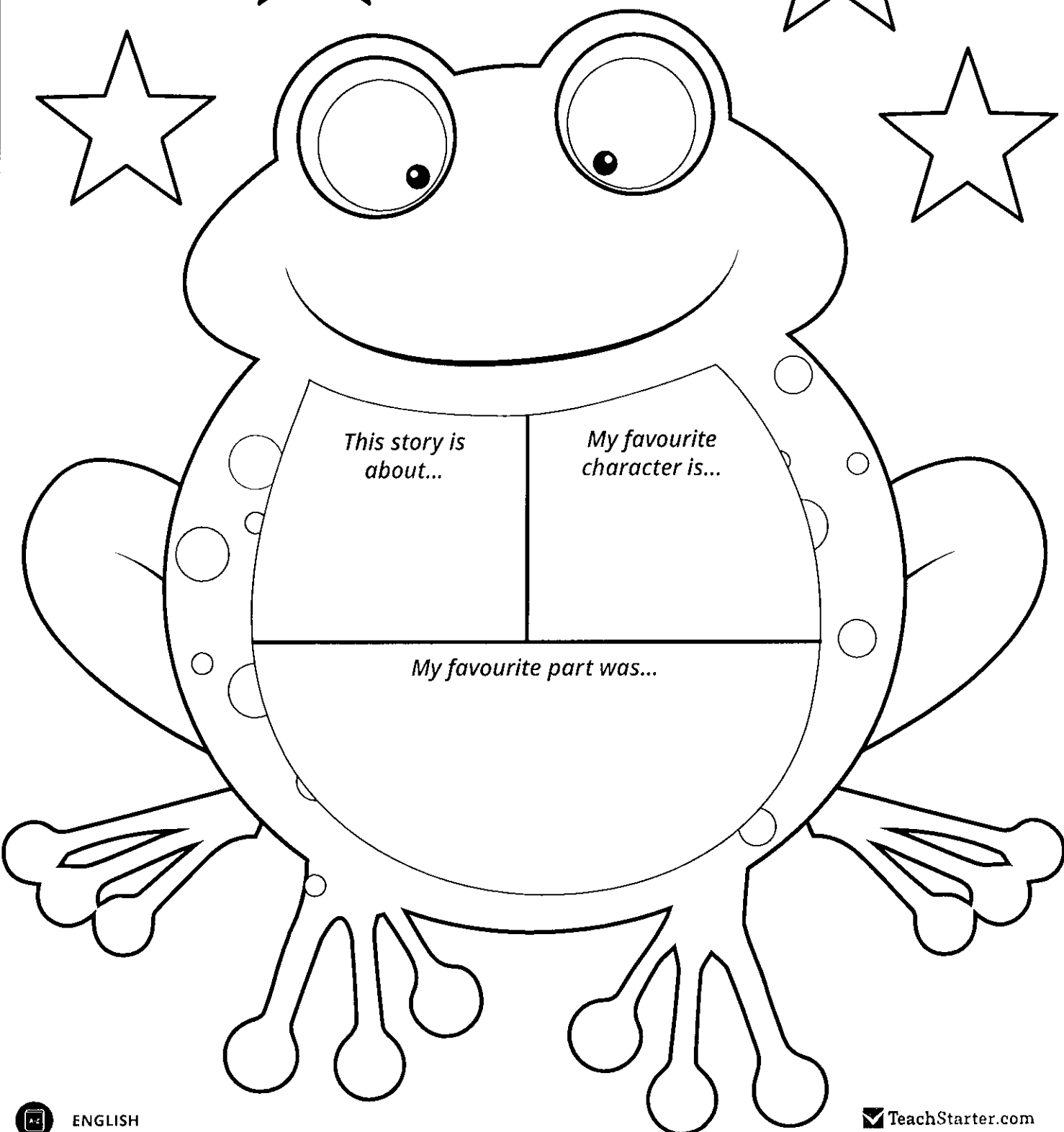
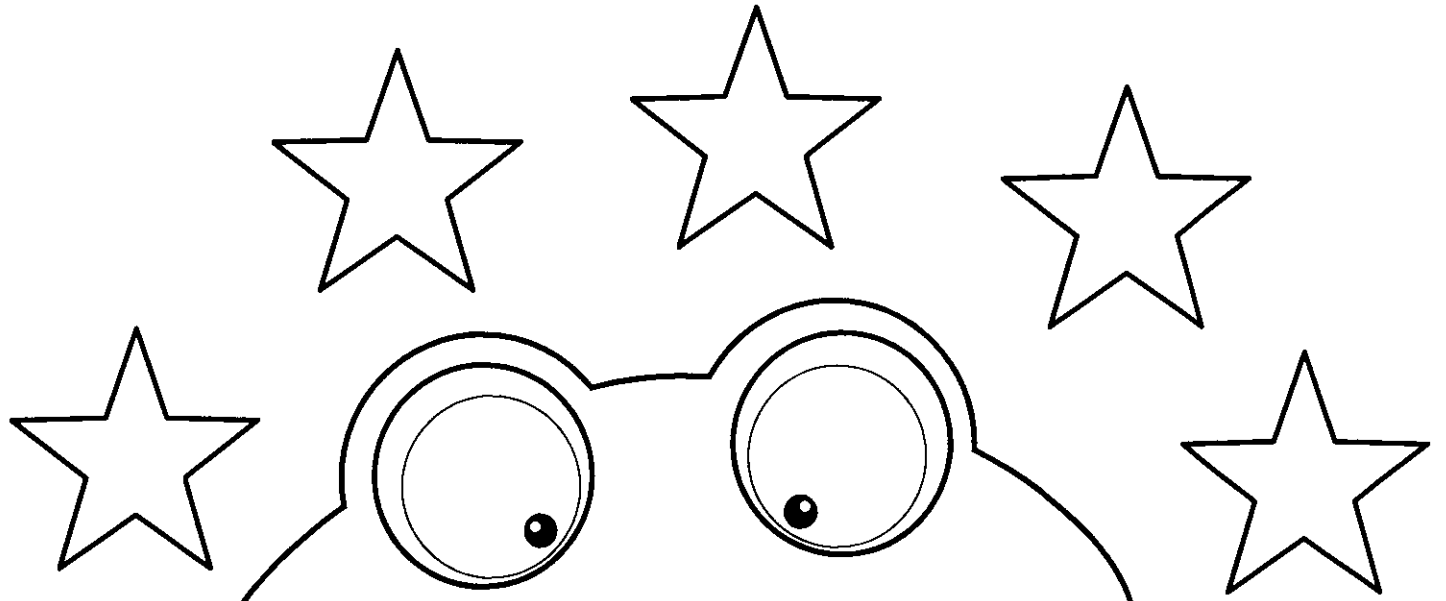

*This story is about...*

*My favourite character is...*

*My favourite part was...*

Name: \_\_\_\_\_

Date: \_\_\_\_\_

© Tiny Teaching Shack

# Make Compound Sentences

Combine two simple sentences to make a compound sentence.

Do you want to eat  
cake

, or

do you want some hot  
cocoa?

simple sentence

conjunction

simple sentence

**Direction:** Circle the correct conjunction to combine the simple sentences.

1. I am very excited, (*so* / *because*) we are going bowling after school!
2. Cats usually don't like water, (*but* / *so*) my cat loves taking a bath.
3. Cory put his tooth under his pillow, (*and* / *or*) he found a coin in its place the next day.
4. He got soaked in the rain, (*because* / *so*) he had to change into new clothes.
5. She got a tummy ache, (*and* / *because*) she had too much ice-cream.
6. We were very good in class today, (*but* / *so*) Mrs. Ronson gave us extra play time.



Name: \_\_\_\_\_

Date: \_\_\_\_\_

**ur**



Complete these words by adding 'ur'.

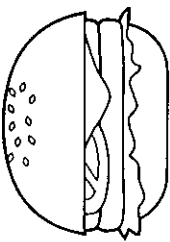

b \_\_\_\_\_ ger



s \_\_\_\_\_ fer

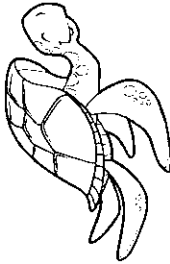

t \_\_\_\_\_ tle

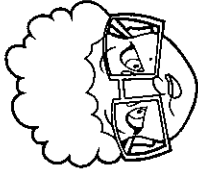

c \_\_\_\_\_ rly



s \_\_\_\_\_ prise

In the word search to the right, find the 'ur' words mentioned above.



Draw your favourite burger below.

b	u	r	g	e	r	q	s
a	c	u	r	l	y	n	u
w	s	f	g	x	z	p	r
t	u	r	t	l	e	h	p
t	r	i	c	n	k	y	r
b	f	u	r	r	y	j	i
d	e	i	r	x	m	m	s
j	r	s	u	e	p	o	e



Name: \_\_\_\_\_

j

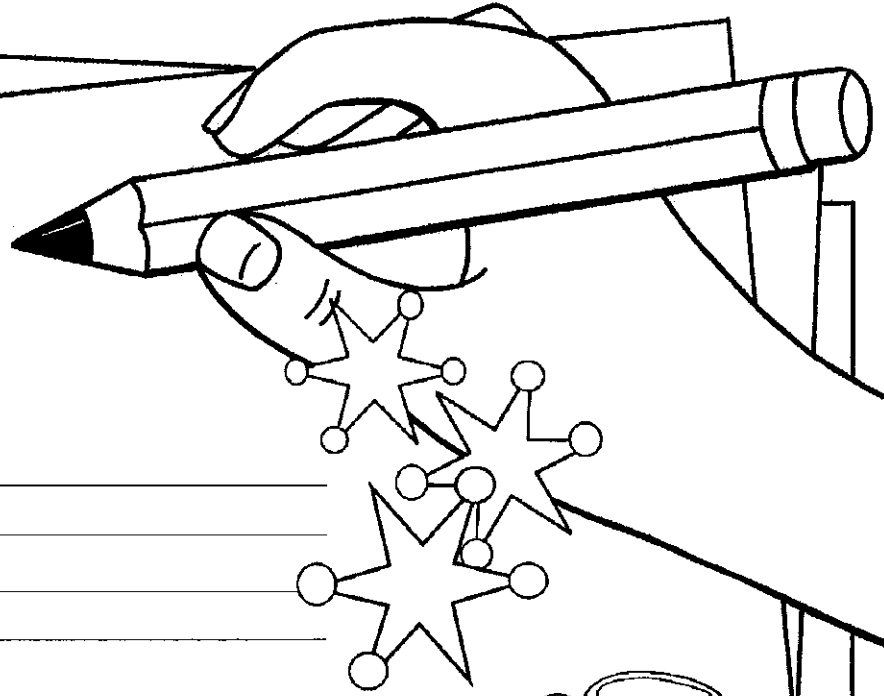

j j j

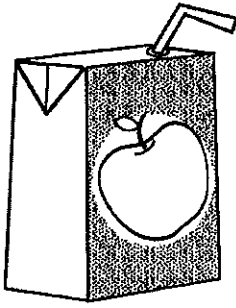

juice

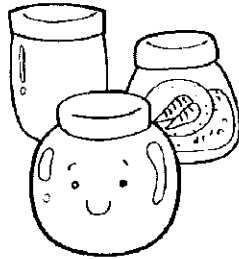

jar

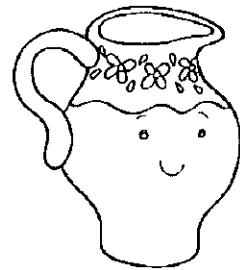

jug



jacket

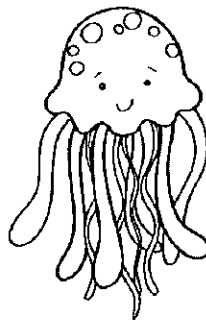

jellyfish



jump

Name: \_\_\_\_\_ Date: \_\_\_\_\_

16  
 sixteeteen

What comes before and after 16?

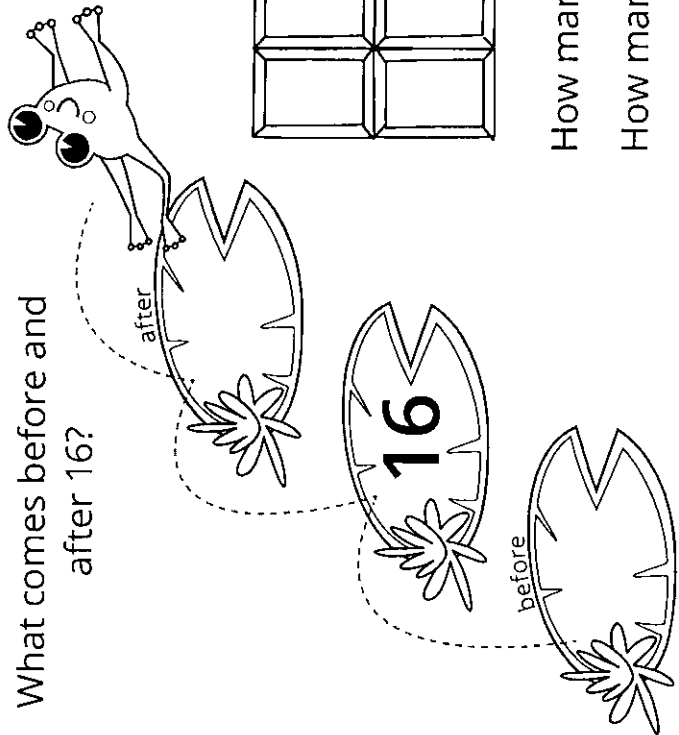

Colour in 16 pieces of this chocolate bar.

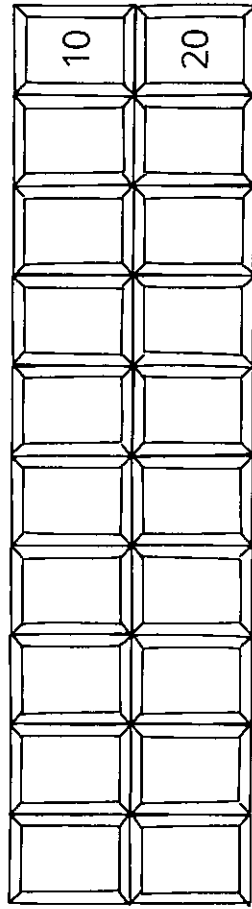

How many chocolate squares more than 10? \_\_\_\_\_  
 How many chocolate squares less than 20? \_\_\_\_\_

Write 16 in the correct houses.

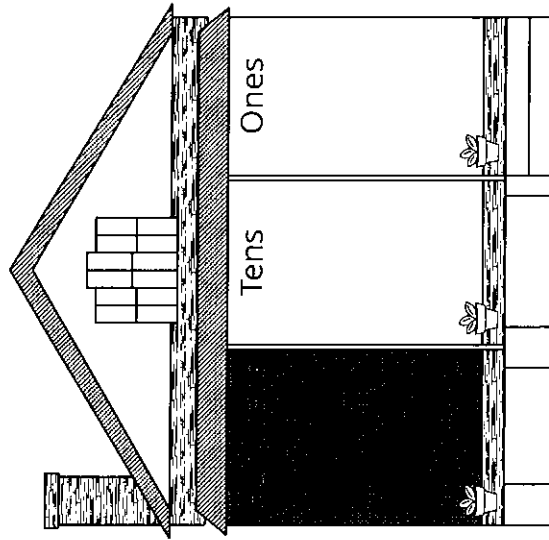

Name: \_\_\_\_\_

# Fill in the Numbers

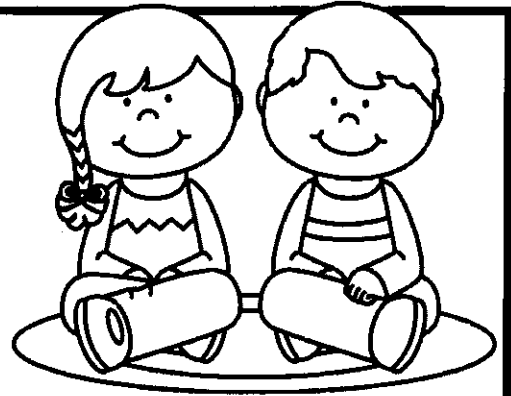

1.	12	13		15		
2.		10	11			14
3.	6			9		
4.		15		17	18	
5.	5		7			10
6.	13	14				
7.		16		18		20

Addition to ten.

Finish in your own colours.

WRITE THE SUM

3 shoes and 6 socks.  
How many altogether?

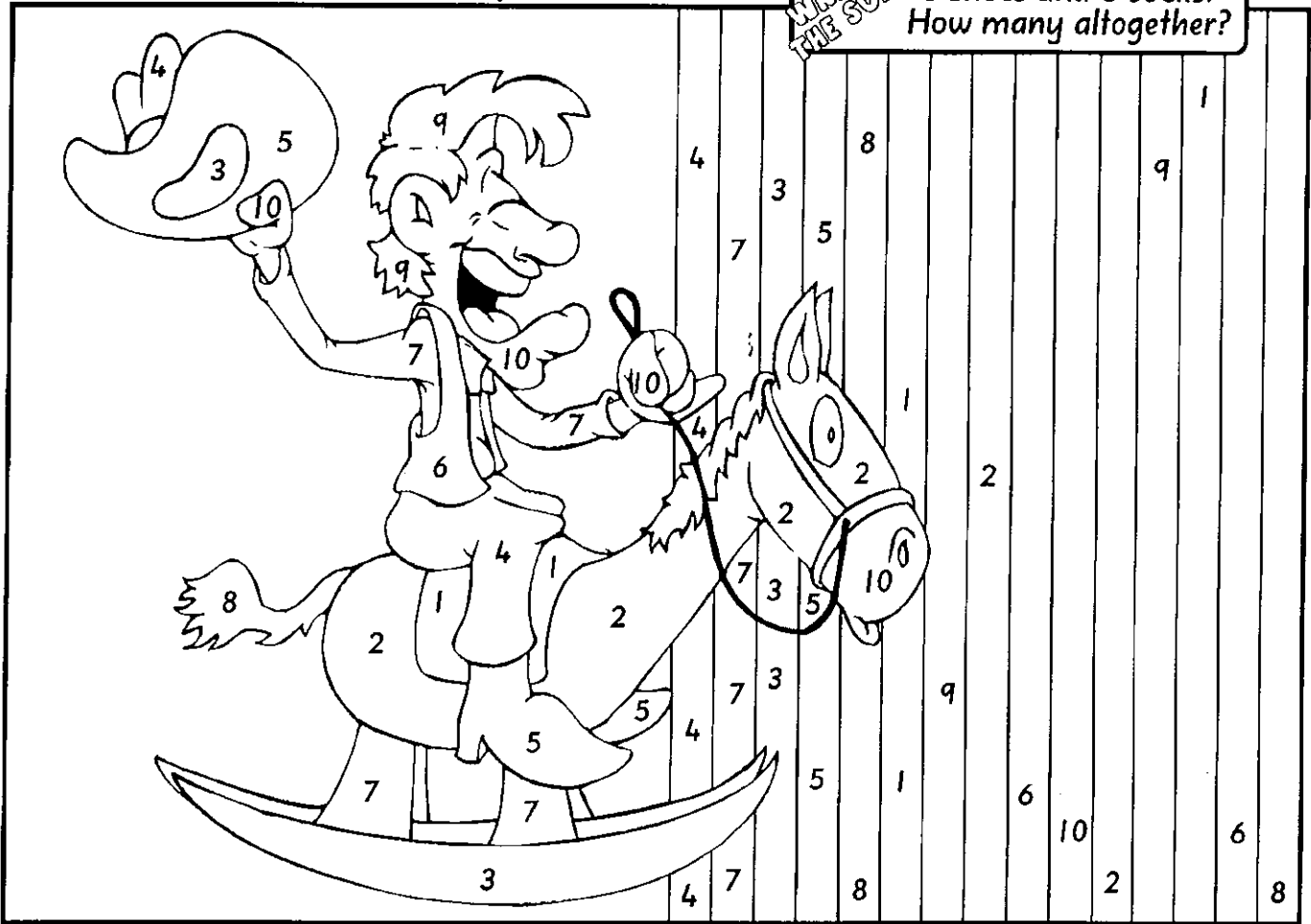

Look for the numbers more than once and colour the picture.

<p>blue</p> $\begin{array}{r} 3 \\ + 3 \\ \hline \end{array}$	<p>green</p> $\begin{array}{r} 0 \\ + 1 \\ \hline \end{array}$	<p>red</p> $\begin{array}{r} 4 \\ + 5 \\ \hline \end{array}$	<p>yellow</p> $\begin{array}{r} 2 \\ + 0 \\ \hline \end{array}$	<p>purple</p> $\begin{array}{r} 3 \\ + 1 \\ \hline \end{array}$
<p>pink</p> $\begin{array}{r} 2 \\ + 8 \\ \hline \end{array}$	<p>orange</p> $\begin{array}{r} 2 \\ + 5 \\ \hline \end{array}$	<p>black</p> $\begin{array}{r} 1 \\ + 2 \\ \hline \end{array}$	<p>brown</p> $\begin{array}{r} 4 \\ + 1 \\ \hline \end{array}$	<p>rainbow</p> $\begin{array}{r} 3 \\ + 5 \\ \hline \end{array}$

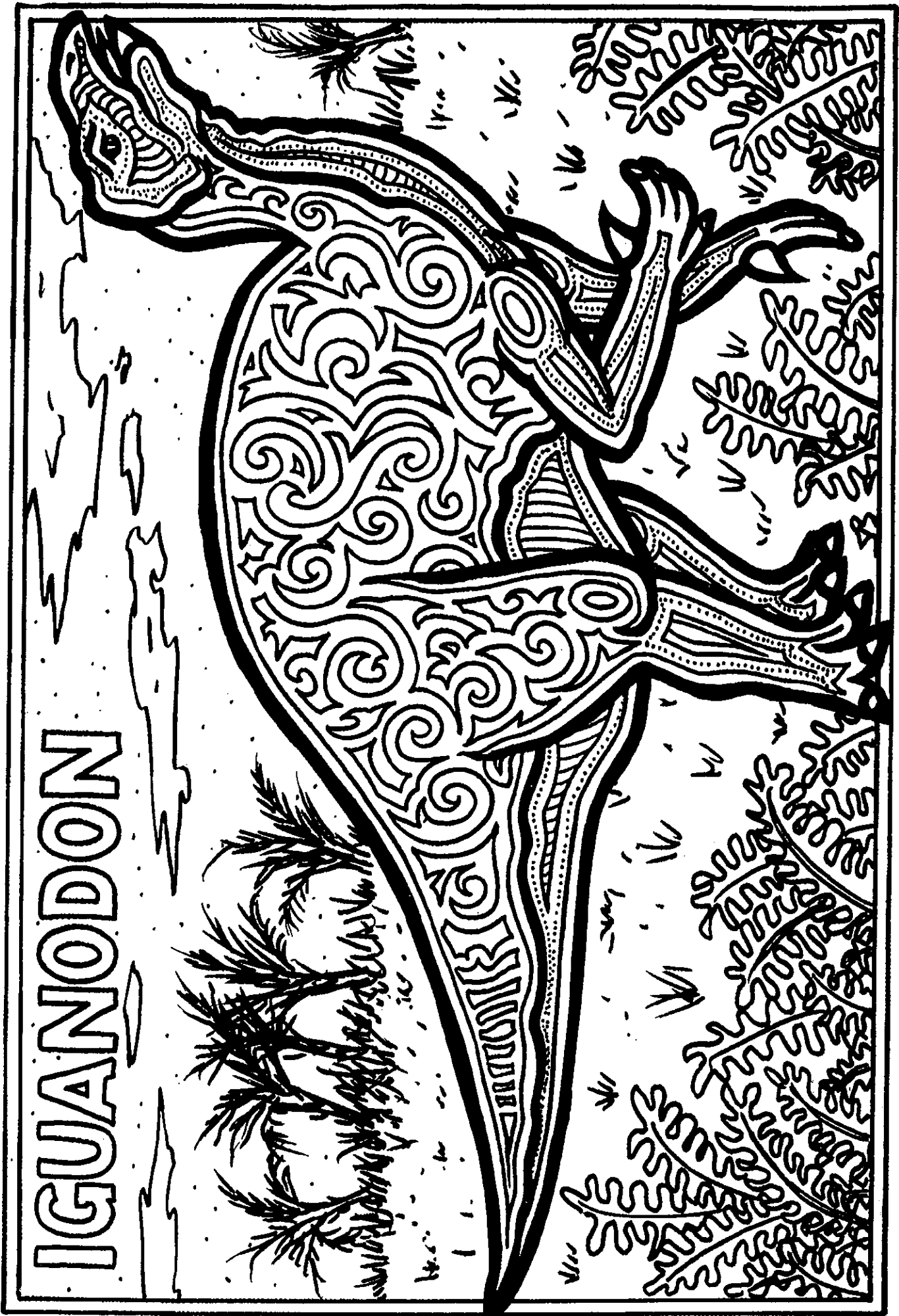

IGUANODON